

RESEARCH

The NP vs. DP debate. Why previous arguments are inconclusive and what a good argument could look like. Evidence from agreement with hybrid nouns

Martin Salzmann

University of Pennsylvania, Philadelphia, PA, US

msalzm@ling.upenn.edu

The DP-hypothesis as proposed in Abney (1987) is nowadays generally taken for granted in formal syntactic work. In this paper I will show that a surprising number of arguments that have been provided in the literature are not conclusive. Many rest on purely theory-internal premises and thus lose their force given the developments within syntactic theory over the last decades. Others are largely based on presumed parallelisms between the noun phrase and the clause. In practically all cases a reasonable reanalysis within the NP-hypothesis is possible. Similarly, I will show that the few arguments in favor of the NP-hypothesis that there can be found are also inconclusive. Instead I will establish solid criteria for headedness and explore their implications for the NP vs. DP debate. I will show that the fact that the features of the head are present on the maximal projection makes testable predictions when the noun interacts with noun phrase external heads. I will first show that data from selection favor the DP-hypothesis (contrary to previous claims) since one needs to be able to syntactically select both DPs and bare nouns/NPs. Second, I will present a new argument in favor of the DP-hypothesis based on data from hybrid agreement in Bosnian-Croatian-Serbian. The phenomenon crucially requires D-elements to be closer to agreement targets outside the noun phrase than the noun itself. This follows if DP dominates NP but not vice versa.

Keywords: noun phrase; agreement; hybrid nouns; agreement hierarchy; selection; idioms

1 Introduction

Until the mid 1980s there was little controversy about the head of the noun phrase in examples like (1). It was taken to be a projection of the noun with determiners occupying the specifier position of N as depicted in (2a). Things changed drastically with Steven Abney's seminal dissertation (Abney 1987) in which he proposed that it is actually the determiner that heads the noun phrase, cf. (2b):¹

(1) The book

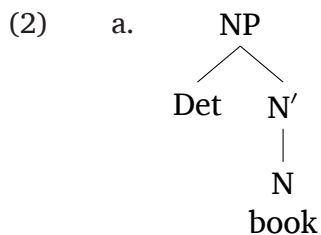

¹ The idea that the determiner is the head of the noun phrase can occasionally be found in literature pre-dating Abney's dissertation, see Abney (1987: 77) for references. However, he was the first to propose a comprehensive new theory of the noun phrase under this perspective.

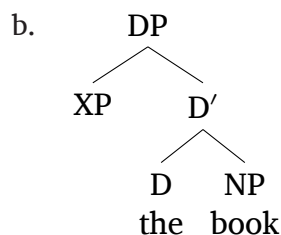

It is fair to say that the DP-hypothesis has been exceptionally successful. In most of the current formal syntactic literature, especially in work carried out within the Minimalist Program since Chomsky (1995), the DP-hypothesis is taken for granted.

Interestingly, though, once one browses through some of the major textbook introductions to various formal syntactic theories, one finds surprisingly little argumentation in favor of either NP or DP. For instance, in their introduction to LFG, Bresnan et al. (2016) remain agnostic as to which structure is preferable. In the introduction to TAG by Frank (2002) the DP-hypothesis is taken for granted but not argued for. Within HPSG, the noun phrase seems to be taken to be an NP; in Sag et al. (2003), this is simply presupposed, while Müller (2007: 84–87) explicitly argues in favor of the NP structure (I return to his argument in Section 3.2 below). In his introduction to Minimalist syntax, Adger (2003) adopts the DP-hypothesis but merely provides constituency arguments in its favor (discussed in Section 2.3 below). The surprisingly little amount of argumentation in favor of either NP or DP strongly contrasts with the discussion about other syntactic categories like APs, PPs, VPs and CPs where there does not seem to be a comparable uncertainty about what the head is.

The scope of the DP-hypothesis was quite clear at the time it was proposed given that little additional structure was posited for the noun phrase. Thus, the question was essentially about whether D or N is the head. Things are different nowadays given that it has become standard to posit a rich functional structure within the noun phrase, including heads such as *n*, number, gender, definiteness etc., see, e.g., Alexiadou et al. (2007) for an overview. Against this background, there are different ways of interpreting and evaluating the DP-hypothesis. One possibility is still to focus on the category D and try to show that it is/is not the head of the noun phrase. This presupposes a good understanding of what D corresponds to. This can be less straightforward, e.g., in languages without articles or languages where determiners and demonstratives occupy different positions. Another possibility is to ask whether N is the head or some other functional head within the noun phrase, which need not necessarily be equated with D. Given the proliferation of functional categories within the noun phrase and the somewhat unclear status of D at least in some languages, I will, to simplify the discussion, focus on whether N is the head (NP-hypothesis) or some other element of the noun phrase. I will keep speaking of the DP-hypothesis in the latter case, even if this may not always be fully accurate. Note also that to be able to compare the NP-hypothesis with the DP-hypothesis, one has to assume that at least some morphosyntactic features of the noun phrase are located on N even in the latter, even though separate functional projections are often posited for those. But if N does not bear any morphosyntactic features, the DP-hypothesis cannot be falsified.

Against this background, the goal of this paper is two-fold. I will first reevaluate the DP-hypothesis by reviewing previous arguments advanced in its favor. As we will see, many arguments cannot be considered conclusive: Some arguments only make sense in the context of the GB-theory at the time and its assumptions about phrase structure. Others are mainly based on presumed parallels between the clausal and the nominal structure. Still other arguments only diagnose constituency/hierarchy but not headedness. As I will

show, under current assumptions, quite a few phenomena can be reanalyzed relatively straightforwardly by means of the NP-structure.

Second, I will establish robust criteria for headedness on a very general level and explore their implications for the question about the head of the noun phrase, viz., the fact that the relationship between heads and complements is asymmetric and that the features of the head are present on the maximal projection. While certain aspects that are sensitive to headedness such as form determination (heads determine properties of their complements) and distribution (the head determines the distribution of the phrase) lead to a somewhat inconclusive result, there are two aspects of headedness that can be used to empirically distinguish between the NP- and the DP-hypothesis. Both rest on the assumption that the features of the head are present on its projections. I will first show that selection (the head is the target for selection by outside elements) favors the DP-hypothesis because one has to be able to select both DPs and NPs/bare nouns. The second argument is based on agreement, which predicts the features of the head to be most visible to agreement targets outside the noun phrase. The relevant phenomenon is hybrid agreement in BCS (Bosnian-Croatian-Serbian), where once a head/probe has agreed in semantic gender with the noun, every higher head/probe has to do so as well, while a switch from grammatical to semantic agreement is possible. I will show that this pattern favors the DP-hypothesis because only then do we expect that heads outside the noun phrase will preferably target features of D as they are closer to those probes than the features of N.

The paper is organized as follows: In Section two, I will discuss previous arguments in favor of the DP-hypothesis. In Section three, I briefly address previous arguments in favor of the NP-hypothesis. In Section four, I first establish good criteria for headedness and then explore their implications for the NP vs. DP debate. Section five concludes.

Before proceeding, let me emphasize that this paper will not take a stand on whether languages can differ with respect to the head of the noun phrase, concretely, whether all languages have DPs or whether some have DPs, while others only project NPs, cf. Bošković (2005), although I will touch upon this issue at various points of the paper. Furthermore, the paper should not be interpreted as implying that the DP-hypothesis is definitely superior to the NP-hypothesis. While the facts discussed in this paper overall favor the DP-hypothesis and many of the arguments that have recently been presented in favor of the NP-hypothesis are inconclusive in my view, some strike me as interesting, suggesting that the issue cannot be settled so easily. The goal of this paper is thus somewhat more modest and methodological in nature, viz., to demonstrate what a good argument for headedness and, consequently, in favor of one of the two hypotheses should look like.

2 Arguments for the DP-hypothesis

In this section I will review a large number of arguments for the DP-hypothesis; this includes arguments that were originally presented in Abney's thesis as well as arguments that can be found in more recent textbooks and overview articles such as Bernstein (2001); Longobardi (2001); Adger (2003); Coene & d'Hulst (2003); Alexiadou et al. (2007); and Punske (2014). The list of arguments will surely not be exhaustive, but I take it to be representative because it includes the relevant *types* of arguments.

There are conceptual arguments that are largely due to specific assumptions of the GB-framework about phrase structure at the time. There are parallelism arguments based on the presupposition that the clausal and the nominal architecture must be very similar. There are constituency arguments showing that N forms a constituent to the exclusion of D. Finally, there are head-movement arguments suggesting that there is an X^0 -position above N. In the last subsection, I will briefly discuss further miscellaneous arguments for the DP-hypothesis.

The constituency arguments can be shown to be irrelevant as they do not diagnose headedness. The head-movement arguments are relevant but strictly speaking do not show that the higher head has to be identified with D or some other functional head. For the conceptual and parallelism arguments, I will argue that there is a reasonable alternative available under the NP-hypothesis (as I will point out below, some of the putative arguments for the DP-hypothesis are also discussed, and rejected, in Bruening 2009 and Bruening et al. 2018). Note that I do not wish to claim that these alternatives are necessarily superior to analyses based on the DP-structure; in fact, in some cases, the NP-alternative will require somewhat less standard assumptions. Nevertheless, I take the alternatives to be plausible enough to regard the arguments for the DP-hypothesis as inconclusive. Of course, a lot will depend on which assumptions are considered acceptable/reasonable and which are not. I will in what follows try to be as explicit as possible about the costs associated with the assumptions necessary under a reanalysis by means of an NP-structure and as neutral as possible w.r.t its comparison with an analysis under the DP-hypothesis. It is nevertheless possible that certain readers will find some of the reanalyses somewhat implausible because of the assumptions made. To me, this disagreement suggests, first and foremost, that the arguments are not strong enough. Ideally, it should be possible to find criteria for the headedness of the noun phrase that most syntacticians agree on.

2.1 Theory-internal arguments

2.1.1 Number of specifiers

The first argument for the DP-hypothesis comes from examples like (3), where in addition to the possessor there is also a prenominal determiner present (such structures are limited in English but frequent in other languages, e.g., Hungarian, cf. Abney 1987: 270–276 and Section 2.2.2 below):

(3) John's every secret wish

Such examples posed a problem under the X'-theoretic assumptions of the Government-and-Binding era because it was assumed that heads only project one specifier (Abney 1987: 288–297). Since both the quantifier and the possessor have to occupy specifier positions of N, analyzing (3) as in (4a) was not an option.² No problems arise under the DP-hypothesis where the possessor occurs in the specifier, while the determiner occupies the D-position, cf. (4b):³

² Note that Jackendoff (1977) had already shown that the restriction to just one specifier is too restrictive. He argued in favor of three bar-levels to account for the range of options within the noun phrase. See also Abney (1987: 290–297) for cases where two XPs occur above adjectives and thus require at least two specifiers within the noun phrase (SpecNP for quantifier/measure phrases, SpecDP for possessors/external arguments).

³ Prenominal adjectives are represented as specifiers of N in (4) for reasons of simplicity, even though Abney (1987: 322–350) actually argues that they are heads taking NP as their complement. See fn. 30 below for further discussion.

Prenominal adjectives are sometimes argued to provide another – indirect – argument for the DP-hypothesis (e.g. Haider 1992: 307): Adjectives are generally treated as adjuncts, which traditionally are adjoined to maximal projections. Furthermore, while D-elements must be unique within the noun phrase, there can in principle be an unlimited number of prenominal adjectives. Under the DP-hypothesis, these properties can be straightforwardly accommodated: There is only one slot for D-elements, while adjectives, as adjuncts, can be iterated (except in Antisymmetric approaches, cf. Kayne 1994). Under the NP-hypothesis, the difference between specifiers and adjuncts is blurred and it thus seems ill-suited to capture the structural difference between adjuncts and non-adjuncts and, as a consequence, the difference in iterability. Unlike adjuncts at the clausal level, adjectives are thus not adjoined to a maximal projection. However, it is not clear that adjuncts always attach to maximal projections. In the verb phrase, at least in languages with flexible word order, there are cases where an adverb occurs closer to the verb than the verb's arguments in unmarked order. Adjunction to an intermediate projection (or, in Bare Phrase Structure terms, a projection where not all features of the head are satisfied) may be the descriptively most parsimonious solution in that case (rather than postulating obligatory movement of the arguments). Against this background, the

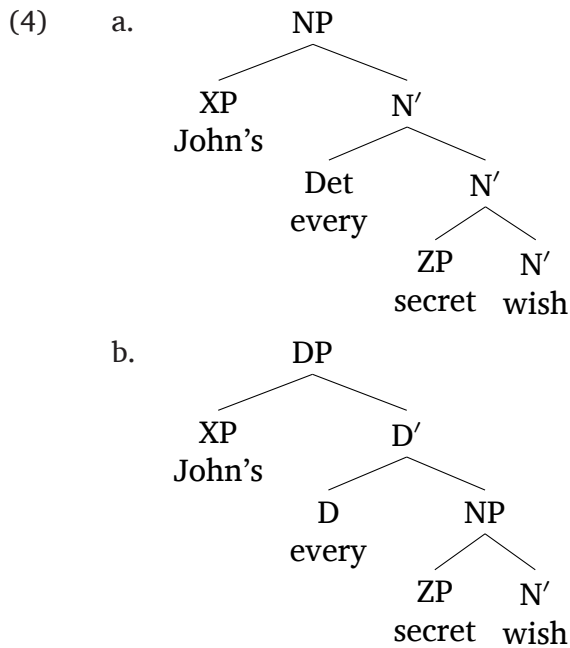

Importantly, the restriction is no longer adhered to in more recent work within the Minimalist Program (though see antisymmetric approaches where for reasons of linearization, heads also take just one specifier, which is treated as an adjunct, cf. Kayne 1994). Even in languages that do not have overt multiple *wh*-movement to the same functional projection it is standardly assumed that at least *v* can take several specifiers: Next to external Merge of the subject, an additional specifier is projected when objects undergo successive-cyclic movement and make an intermediate movement step via Spec v P:

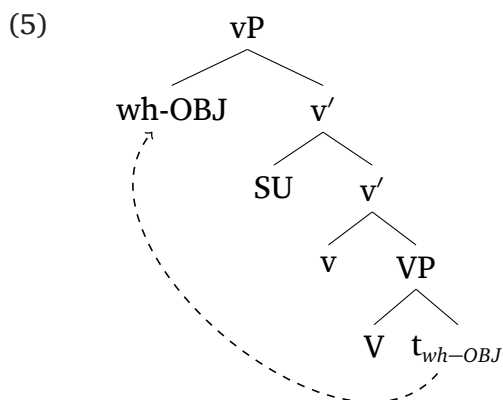

structural integration of adjectives under the NP-hypothesis may not be so exotic after all. The recursivity/non-recursivity of Ds and As, respectively, can arguably be captured semantically since the two elements differ in semantic type: While adjectives are predicates and thus of type $\langle e,t \rangle$, they can be iterated via predicate modification. Determiners, however, are of type $\langle \langle e,t \rangle, e \rangle$; they combine with predicates and return elements of type $\langle e \rangle$. After that, application of another D-element is not possible. Note that handling iterability by means of semantics rather than syntactic category and structural integration may be independently necessary in analyses of languages like Serbo-Croatian where quantifiers and demonstratives are morphologically adjectives and therefore are categorized accordingly. Since they nevertheless cannot be iterated unlike descriptive adjectives, some other means to capture the distribution/combinatorial possibilities is necessary. I will come back to the role of semantics in determining properties of the noun phrase further below in this section. For the categorization of NP-modifiers in languages like Serbo-Croatian, see also the discussion in Section 4.3 below.

Note, finally, that the analysis of (4b) is not compatible with the assumption that the possessive suffix occupies the D-position; if that assumption is to be upheld, an additional functional projection is required to host the quantifier.

Several specifiers of *v* are also often posited for languages with free word order; for German, for instance, it has been argued that multiple scrambling can target different specifiers of *v*, see Heck & Himmelreich (2017).

One may object that under the DP-hypothesis, the word order restrictions, i.e., the fact that the possessor precedes the determiner and the determiner the adjective, follow more straightforwardly than under the NP-hypothesis: The specifier of D precedes the head D and D precedes adjuncts adjoined to NP. However, since there are also languages where the possessor can follow the determiner (see below on Hungarian), this does not strike me as a very strong point. In that case, one has to postulate another functional projection below D which can host the possessor. Under the NP-hypothesis, one will have to treat determiners and possessors as optional arguments that have to be introduced in a certain order. Thus, while under the DP-hypothesis the order results from the functional sequence (and possible movement operations of the possessors), under the NP-hypothesis, the order follows from ordered selectional features on N. The fact that D-elements precede adjectives need not be stipulated under the NP-hypothesis but follows from the semantics (see also Bošković 2009): D-elements close off the noun phrase by mapping a predicate onto an individual. The reverse combination is simply impossible. Note also that semantic considerations are inevitable even under the DP-hypothesis given that adjectives also occur in a preferred order according to a semantic hierarchy, see Scott (2002). Thus, unless one adopts a cartographic approach, the DP-hypothesis will also have to resort to semantics to account for some ordering restrictions within the noun phrase.

2.1.2 Distribution of D-elements and consistent selection

The next theory-internal argument comes from selection and the distribution of D-elements. First, verbs can be combined with both nouns/noun phrases and pronouns. Since pronouns belong to category D, consistent selection by the verb favors treating noun phrases as DPs (Abney 1987: 74, 281–284). Importantly, pronouns are sometimes reanalyzed as determiners taking a silent NP-complement (Elbourne 2005), cf. (6a). However, once parts of the noun phrase can be silent, one can reanalyze pronouns as NPs headed by a silent N that take a D-specifier (or D-complement under Bare Phrase Structure), cf. (6b) (unless there is an independent restriction that only maximal projections can be silent, see Section 2.3.1 below; cf. also Abney 1987: 278–281):

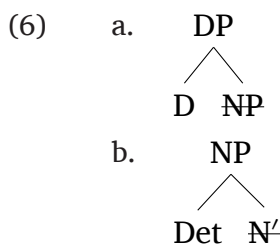

Essentially the same issue arises with demonstrative pronouns, which have the same distribution as noun phrases with demonstrative determiners. Capturing the identical distribution is straightforward under the DP-hypothesis; however, once we allow the head N to be silent, the distribution also follows under the NP-hypothesis, cf. (7):⁴

⁴ Haider (1992: 311–312) argues that differences in the position of modifiers between personal pronouns and nouns in German provide an argument for the DP-hypothesis. The basic observation is that while nouns can be modified to the left and to the right, personal pronouns can take modifiers only to the right. In fact, the empirical situation is somewhat more complex: Personal pronouns can be modified only to the right, while with noun phrases and, importantly, demonstrative determiners, the modifier can occur on either side, cf. (i) (note that determiners and demonstrative pronouns are homophonous):

- (7) a.
$$\begin{array}{c} \text{NP} \\ \swarrow \quad \searrow \\ \text{D} \quad \text{N}' \\ \text{this} \end{array}$$
- b.
$$\begin{array}{c} \text{NP} \\ \swarrow \quad \searrow \\ \text{D} \quad \text{N}' \\ \text{this} \quad \text{man} \end{array}$$

The argument in this subsection crucially rests on the assumption that noun phrases and pronouns in the same language are of the same syntactic category. Therefore, it loses much of its force once it is possible for a verb to occur with nominal complements that

-
- (i) *German*
- a. mit dem Mantel {die (Frau)/ *sie}
with the coat the/this woman she
'the one/the woman/she with the coat'
- b. {die (Frau)/ sie} mit dem Mantel
the/this woman she with the coat
'the one/the woman/she with the coat'

In addition, personal pronouns can only be modified by adjuncts; they disallow argumental modifiers such as possessors on either side, while possessors are grammatical with noun phrases and demonstrative pronouns (on both sides), cf. (ii):

- (ii) *German*
- a. von Hans {die (Frau)/ *sie}
of John the/this wife she
'John's (wife)'
- b. {die (Frau)/ *sie} von Hans
the/this wife she of John
'John's (wife)'

The pattern for personal pronouns can be accounted for if the personal pronoun replaces the entire DP and there is thus no silent NP (as argued for in Wiltschko 1998: 149). As a consequence, any modifier has to be adjoined, which in the German noun phrase always implies right-adjunction. The absence of modification by possessors follows as well under this analysis if possessors have to be generated in a lower NP-internal position, which would be absent in personal pronouns. With noun phrases, however, possessors can be generated within NP and appear postnominally or move to Spec,DP and appear prenominal; adjuncts can either be projected in Spec,DP (there can be at most one phrasal modifier preceding D-elements) or adjoined to the right. The pattern with demonstrative pronouns follows if there is NP-ellipsis as in (7); we thus correctly expect the same pattern as with noun phrases.

However, once NP-ellipsis is assumed for personal pronouns as well as in the structures in (6), the asymmetries w.r.t. both nouns and demonstrative pronouns are unexpected. One possibility to account for the asymmetry is to assume that zero realization of the NP in the case of personal pronouns is no longer possible once extraction has taken place from within NP, i.e., once NP contains a trace. Why no such restriction holds for demonstrative pronouns is not immediately obvious; one possibility (to be explored in the future) is to relate this to the fact that, at least in German, the demonstrative pronoun is morphologically identical to the demonstrative determiner, while the relationship between definite determiner and pronoun is suppletive.

Patel-Grosz & Grosz (2017: 275–276) try to relate various differences between personal pronouns and demonstrative pronouns (which on their analysis both take a silent NP-complement) to differences in the definite article contained in them, basing themselves on the distinction in Schwarz (2009): A weak article in personal pronouns and a strong article in demonstrative pronouns. While this may account for distributional differences and why personal pronouns cannot be modified by restrictive relative clauses (restrictive RCs are generally incompatible with the weak determiner), the PP-modification asymmetry above remains unaccounted for.

The implications of the facts discussed in this footnote for the NP vs. DP debate are the following: They suggest that pronouns are of a different category than nouns; together with the fact that an NP-ellipsis of personal pronouns is problematic, consistent selection is no longer possible under the NP-hypothesis since verbs can combine with both nouns/noun phrases and pronouns.

can be shown to be different from DP. This is, for instance, the case if different types of pronouns correspond to different categories, as argued in Déchaine & Wiltschko (2002), who distinguish ϕ P, nP and DP. Thus, if a predicate is compatible with different pronouns and thus different XPs, one might as well assume that in addition, it is also compatible with NPs. The issue also arises with noun phrases, where there is a debate about whether all noun phrases are necessarily of the same size within the same language. The case is particularly pressing with bare nouns, where the postulation of silent structure is contested. Once verbs can also occur with noun phrases of smaller size, e.g., NumP or even NP, the argument from consistent selection is further weakened. See Section 4.2.1.1 below for more discussion on selection of potentially different types of noun phrases.

2.1.3 Projection

Another conceptual argument for the DP-hypothesis comes from projection: Under the NP-hypothesis, Det seems to be the only category that does not project (by taking complements), cf. Abney (1987: 288–289). However (cf. Bruening 2009: 31), this is no longer an issue under Bare Phrase Structure as adopted in the Minimalist Program (Chomsky 1995), where heads that do not take complements/specifiers are minimal/maximal and empty intermediate projection levels are no longer necessary. Quite apart from this, similar issues arise with other nominal modifiers like numerals or quantifiers, which also do not take complements under the NP-hypothesis. Furthermore, the assumption that every category has to project by taking complements cannot be generally correct once we take adverbs into account: They have traditionally been assumed to project and attach to maximal projections, even though they usually do not project via selection of a complement.

2.2 Parallelism arguments

This subsection deals with several arguments that are based on parallelism between the verbal and the nominal domain. The argument usually goes like this: Given that we find X in the verbal domain/X is a functional head in the verbal domain, its counterpart in the nominal domain should also be a functional head. As we will see, while these arguments are not per se implausible, there is always an analytical alternative under the NP-hypothesis.

2.2.1 Agreement – on functional heads only

The first argument is based on the observation that in some languages we find possessor agreement on nouns (Abney 1987: 37–52), which in some languages additionally looks morphologically identical to agreement at the clausal level, viz. on the T-head. From this it is concluded that there must also be a corresponding functional head in the nominal domain. Consider the following data from Yupik Eskimo discussed in Abney (1987: 39–42):

- (8) *Yupik*
- a. angute-t kiputa-a-t
 man-ERG.PL buy-OM.SG-SM.PL
 ‘The men bought it.’
- b. angute-k kiputa-a-k
 man-ERG.DU buy-OM.SG-SM.DU
 ‘The men (du) bought it.’
- (9) *Yupik*
- a. angute-t kuig-a-t
 man-ERG.PL river-SG-AGR.PL
 ‘the men’s river’

- b. angute-k kuig-a-k
 men-ERG.DU river-SG-AGR.DU
 ‘the men’s (du) river’

The markers that reference agreement with the ergative argument in (8) are identical to those that reference agreement with the possessor in (9). Upon closer inspection, however, it becomes clear that the parallelism is not as perfect as it may seem at first sight: Crucially, the object marker in the verbal paradigm in (8) occupies the same slot as the marker which encodes the noun’s inherent ϕ -features in (9). If we were to interpret the parallelism in a very strict way, we would be led to the rather questionable conclusion that the possessee occupies the equivalent of an object position in the nominal domain (see Bruening 2009: 32 for the same argument based on Passamaquoddy). It is also important to stress that the perfect morphological parallelism shown in the examples above is by no means found in all languages with possessor agreement; quite often, the agreement markers in the verbal and the nominal domain are different, cf., e.g., Turkish.

Possessor agreement is usually handled by positing a DP with the D-head equipped with a ϕ -probe that targets the possessor in its specifier (the possessor is usually assumed to be extracted from a lower position, e.g., from Spec,nP or Spec,PossP, cf. Adger 2003). Movement of the noun/possessee via Poss to D then ensures that the agreement affix ends up on the noun:

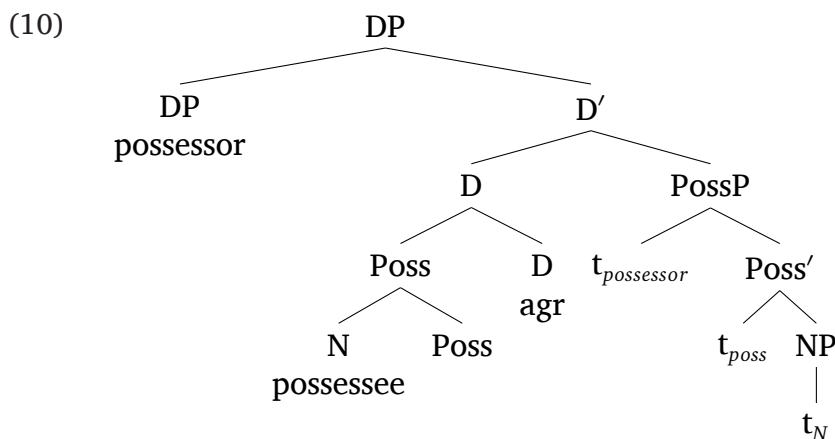

However, these facts can also be captured under the NP-hypothesis once we locate the ϕ -probe on N:

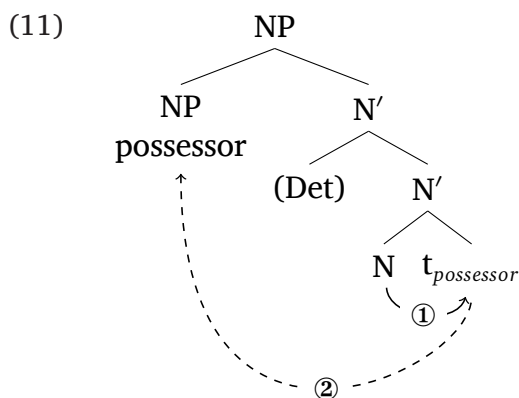

Note that under current assumptions agreement no longer requires a spec-head relationship (as was presupposed at the time of Abney 1987). Rather, c-command between probe

and goal at some point of the derivation is sufficient (for an application to case assignment in the nominal domain, see Georgi & Salzmann 2011). Consequently, the correct result obtains as long as the possessor is c-commanded by the noun at some point of the derivation; this requires possessors to originate within the projection of the possessee and movement of the possessor can no longer be linked to the Agree operation with D. The trigger for movement of the possessor and an analytical alternative will be discussed in the next subsection. As for projecting the possessor within NP, and even as a complement as in (11), this may seem unusual given that nowadays, possessors are usually projected in a functional layer above NP such as nP or PossP. But such layers are usually also largely motivated by parallelism (the possessor is treated as the equivalent of the external argument of the verb). From a purely empirical point of view, though, no problems arise if the possessor originates lower. I am not aware of any evidence, analogous to those at the clausal level (cf. external vs. internal arguments of verbs), that would show that the possessor must be generated outside the projection of the noun. As discussed in fn. 14, when several arguments and/or a possessor of N are present, they are projected in a fixed hierarchy. But nothing, to my knowledge, requires the distinction between projecting an argument within NP and outside of NP. Since restricting phi-probes to functional heads is a purely theory-internal assumption, nothing seems to preclude a reanalysis within the NP-hypothesis.⁵

Related to the agreement argument is the argument based on silent pronouns. It has been observed that possessor agreement, like agreement on T, licenses a silent *pro*. Consider the following pair from Hungarian, cf. Coene & d’Hulst (2003: 5):

- (12) *Hungarian*
- a. a *pro* kalap-unk
the hat-POSS.1PL
'our hats'
 - b. a mi kalap-unk
the we.NOM hat-POSS.1PL
'OUR hats'

In the absence of an overt possessor the inflection is interpreted as pronominal, cf. (12a). In the presence of an overt pronoun an emphatic interpretation obtains, cf. (12b). This is parallel to what is found in pro-drop languages at the clausal level, cf. the following pair from Italian:

- (13) *Italian*
- a. *pro* Canta.
sing.PRS.3SG
'He/she sings.'
 - b. Lui canta.
he sing.PRS.3SG
'HE sings.'

⁵ Even if we were to postulate a higher layer for possessors, n could do the work done above by N. Thus, a D-layer would still not be necessary.

As the examples from Yupik show, the number features of the possessee occur closer to the noun than the agreement features. Given the simple structure above, this will require the number features to be located on N as well.

While there is indeed an obvious parallelism, the assumption that *pro* is only licensed by agreement on functional categories is a purely theory-internal assumption.

2.2.2 Possessors in different positions

At the clausal level there is solid evidence for two subject positions in many languages (cf., e.g., expletive *there* constructions in English; for more evidence, see, e.g., Hornstein et al. 2005: 80–90). Concretely, it is generally assumed that the subject is introduced in SpecvP and moves from there to SpecTP:

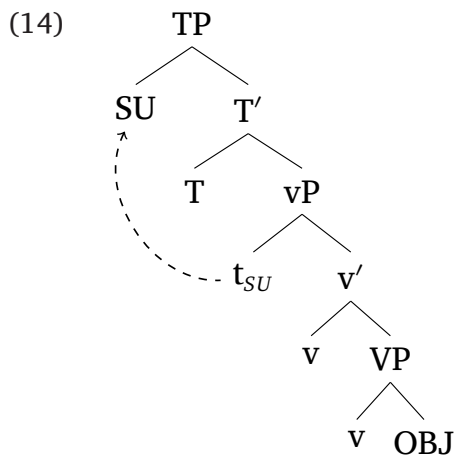

The following pair from Hungarian shows that possessors can occur both below and above the definite article; the alternation correlates with differences in case-marking: the higher possessor bears dative, while the lower occurs in nominative case (cf. also Abney 1987: 275):⁶

- (15) *Hungarian*
- a. a Mari kalap-ja
the Mari.NOM hat-POSS
'Mari's hat'
- b. Mari-nak a kalap-ja
Mari-DAT the hat-POSS
'Mari's hat'

We thus have evidence for two different surface positions for possessors in the noun phrase.

Given the parallelism with the clausal domain, it seems straightforward to argue in favor of movement of the possessor from a lower position closer to the possessee to a higher specifier position associated with a functional head, e.g., SpecDP. In fact, things are more complex in that the possessor in the lower position precedes other noun phrase internal material such as numerals, quantifiers and adjectives in Hungarian. Thus, both surface positions of the possessor are derived. Assuming that the possessor is merged in Spec,PossP, it will then either move to the lower Spec, e.g., Spec,AgrP, or the higher one, viz., Spec,DP, as in (16):

⁶ The discussion of Hungarian possessors is simplified for present purposes; see Kiss (2002: 157–175) for a summary of the literature and relevant references.

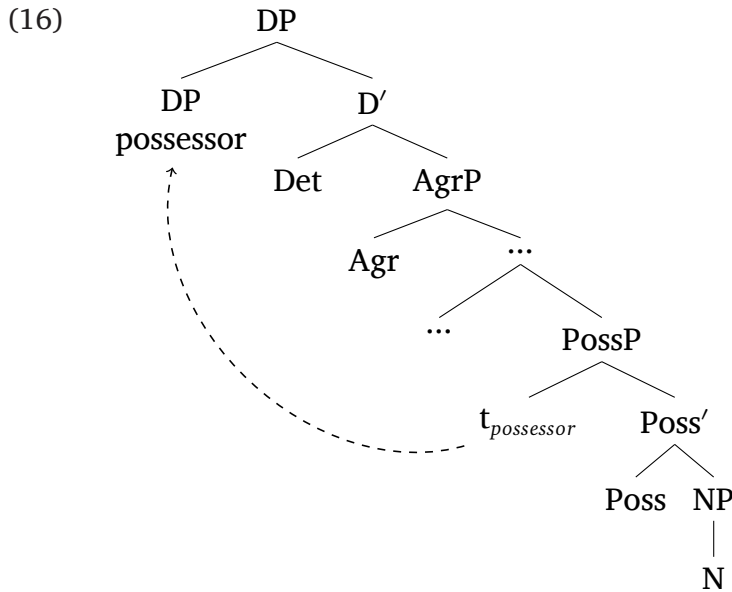

However, strictly speaking, the Hungarian data above only show that the dative possessor is structurally higher than the definite article which in turn is higher than the nominative possessor. They do not show that the possessors have to occupy the specifiers of a higher head. Moving the dative possessor from a lower complement position within NP, e.g., the complement of N, to the highest specifier of N is not a priori ruled out:

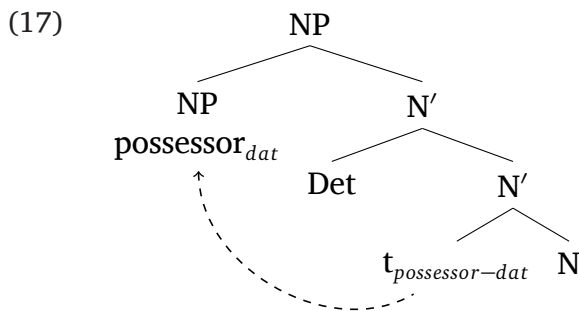

Admittedly, triggering such a movement may be somewhat difficult, but one could adopt a rule that assigns to dative-assigning nouns an EPP-/edge feature that triggers movement to the highest specifier of N.⁷

Alternatively, it is conceivable that possessors can be base-generated in different positions within NP depending on their case-feature. This will be sufficient for the possessor to receive a theta-role from N. One may regard an approach where the order is exclusively handled by means of ordered selectional features of N as ad hoc. However, note that much of the ordering could follow from general principles such as a hierarchy of features and semantics. One should bear in mind that under the DP-hypothesis, the order of functional heads also has to be stated somewhere, e.g., by means of selectional features on the relevant functional heads. As far as I can tell, the major difference would

⁷ Obviously, this kind of movement will be ruled out if movement is subject to the anti-locality requirement as proposed in Abels (2012). One would have to reformulate it for the noun phrase, e.g., such that movement must cross a certain number of (here: intermediate) projections – as is often used to account for *that*-trace effects – or must not touch down too often in a certain domain, cf. Grohmann (2003).

Note that under the DP-hypothesis, one will also have to stipulate a connection between a dative case feature on D and an EPP-feature. Furthermore, one has to connect these features to the presence of a possessor, which is introduced by a different head. Under the NP-hypothesis, where the possessor is introduced by N, this connection is arguably easier to state.

be that the different surface orders of the possessor are derived by movement under the DP-hypothesis and by base-generation under the NP-hypothesis (in the version that does not employ the movement in (17)). Note that I am not aware of any empirical evidence that would clearly show that a possessor in a high position has to have been merged in a low position and moved to its surface position. In the clausal domain, however, floating quantifiers or scope ambiguities (e.g., w.r.t. negation) can provide evidence that the two subject positions are indeed related by movement. Thus, while perhaps unusual, it is not clear to me that an account that largely involves base-generation is necessarily inferior.

2.2.3 SpecDP as an A'-position

It is generally assumed that long-distance movement in the clause proceeds via the specifiers of functional heads, concretely at least via SpecCP (and, according to the current majority view, also via SpecvP, see Chomsky 2001):

(18) Who do you think [_{CP} ₋₁ that Mary likes ₋₁]?

To escape from a certain constituent, the extractee thus has to move via the edge of that constituent. Comparable evidence has also been found in the noun phrase. Possessor extraction in Hungarian is only possible if the possessor bears dative case (recall that this is the case borne by the possessors that precede the determiner in the Hungarian noun phrase:

- (19) *Hungarian* (Alexiadou et al. 2007: 135)
- a. Mari-nak₁ PETER látta [_{DP} ₋₁ a kalap-ja].
 Mari-DAT Peter saw the hat-POSS
 'Peter saw Mary's hat.'
- b. *Mari₁ PETER látta [_{DP} a ₋₁ kalap-ja].
 Mari.NOM Peter saw the hat-POSS
 'Peter saw Mary's hat.'

Given the parallel with the clausal domain, this has been taken as evidence for movement via the specifier of a functional projection, viz. SpecDP, which can consequently function as an A'-position.

Again, the argument is not unreasonable, but an alternative under the NP-hypothesis seems available as well: Note that it has been argued that NP can also be a phase in some languages (those that lack definite articles). Bošković (2016), who investigates restrictions on left-branch extraction, shows that it is only the outermost specifier of N that functions as an escape hatch. Such a definition would also work for the case at hand (I will briefly come back to Boskovic's NP-DP approach in Section 2.5 below).

2.3 Constituency arguments

The arguments in this subsection (from Adger 2003: 247) show that the noun forms a constituent together with certain modifiers, to the exclusion of D-related elements. This is crucially different from showing that D is the head.

2.3.1 NP-ellipsis/one-substitution

It is a well-known fact that English VP-ellipsis is licensed by elements in T such as modals or the emphatic dummy verb *do*:

(20) John likes this book and I do ~~like this book~~, too.

NP-ellipsis is generally taken to be licensed by D-related elements such as demonstratives:

(21) John likes these red books and I like those ~~red books~~.

Given the parallelism with VP-ellipsis, it is thus concluded that the licensing D-element is the head of the noun phrase. The same type of argument has been made with **one**-pronominalization, which is also licensed by certain D-elements:

(22) a. These **expensive bottles** of wine should be drunk.
b. These **ones** should be drunk.

However, these arguments primarily show that N forms a constituent with its prenominal adjectival modifiers (N' is a constituent as well), to the exclusion of D. They only represent an argument for the head-status of D if it is additionally assumed that ellipsis must target a maximal projection. This assumption is problematic for various reasons. First, sluicing, which is usually treated as TP-deletion, usually deletes C-related elements such as complementizers as well. Second, it is not the case that ellipsis always affects the entire maximal projection; adjuncts to the elided constituent can survive ellipsis. This is both the case in VP-ellipsis (cf. *I read the book in the bedroom and Mary did in the living room*) and crucially NP-ellipsis, where adjectival modifiers are deleted only optionally (*I like the red shoes and John likes the blue ones*).

Furthermore, NP-ellipsis is not licensed by all D-elements (singular demonstratives do not in English) and crucially, it is not exclusively licensed by D. It is nowadays taken for granted that nominal ellipsis can involve constituents of different sizes, including NumP, nP or RootP, each licensed by an [E]-feature on a higher head, see Saab (2019) for discussion and references. D is thus not privileged in any way. Furthermore, nothing in the theory of [E]-features necessarily requires the [E]-feature to be placed on the head of the phrase. It might as well be put on a head in a specifier of N and trigger deletion of its N'-complement.

2.3.2 Coordination

It has been observed that the constituent consisting of A + N can be coordinated, with a D-element having scope over both:

(23) These [young dogs] and [old cows].

This is sometimes considered evidence that D is a head (which in (23) would take coordinated NPs as its complement). However, coordination is a constituency test, not a test for phrasal status. Under the NP-hypothesis, the coordinated strings are also constituents, viz., N'-projections. Note that X'-categories can in principle be coordinated, as the following example with subject-ATB-movement shows:⁸

(24) This girl in the red coat [_T will _ eat her breakfast] and [_T will _ put a picture of Bill on your desk before tomorrow].

⁸ Split topicalization in German as in (i) is sometimes taken as evidence for the DP-hypothesis because the NP, possibly with associated adjectival modifiers and quantifiers, can apparently be subextracted from the noun phrase, thereby stranding the determiner (and possibly numerals, quantifiers and prenominal adjectives):

(i) *German*
Roten Wein trinke ich keinen (billigen).
red wine drink I no cheap
'I don't drink any (cheap) red wine.'

If one wants to adhere to the standard assumption that movement is confined to maximal projections, the NP-hypothesis is indeed in trouble here because it seems that one is moving an N'-constituent. However, there is reason to believe that the subextraction analysis is misguided. As discussed in Ott (2015), there are examples of 'split topicalization' where each part is a fully fledged noun phrase so that an extraction analysis is unavailable.

2.4 Head-movement evidence

The data discussed in this section show that there has to be another head-position above the base position of the noun. As we will see, this does not necessarily imply that this head is to be identified with D or some other functional head.

The literature contains quite a number of arguments for head-movement within the noun phrase, one of the first being put forward by Ritter (1988), who posited N-to-D-movement to account for the NSO-order in Hebrew construct state nominals; see, e.g., Carstens (2017) for a recent overview. Since the facts are quite well-known, I limit myself to just one example:

The following Italian data show that the determiner precedes the possessive adjective, cf. (25a/b). While the possessive adjective normally precedes the noun, cf. (25b), the order is crucially reversed if there is no overt D-element, cf. (26a vs. b).

- (25) *Italian*
- a. *mio il Gianni
my the John
'my John'
- b. il mio Gianni
the my John

- (26) *Italian*
- a. *mio Gianni
my John
- b. Gianni mio
John my

The alternation between (25b) and (26b) is consequently argued to result from movement of N to D:⁹

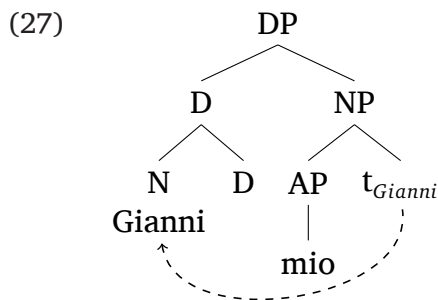

The data indeed suggest that there must be a head-position above the projection of the noun. However, even if we accept this conclusion,¹⁰ this need not necessarily imply that

⁹ It is far from trivial to explain why this movement has to take place. Originally, it was argued that D has to be filled, either by merging an overt D or by raising the noun to D *by substitution* (Longobardi 1994: 641). Given those assumptions, determiner and proper name were in complementary distribution. However, given an implementation of head-movement as adjunction and a post-syntactic approach to morphology, cf. Halle & Marantz (1993), it is no longer obvious why there should be this complementary distribution: Unlike in Longobardi's approach there are now two terminals, viz., N and D in the complex D-N-head, not just one; furthermore, no reference can be made to the overtness of D. One either would have to say that movement is optional, leading to a converging result if D is realized as zero and to a crash if D is overt (e.g., because the overt determiner is not an affix). Non-movement could be argued to crash in case D is silent as it would fail to have a host (which requires treating it as a silent affix) or because some filter requires an overt element in the complex D-N-head. Alternatively, one would have to postulate two different D-heads with only one of them triggering N-raising.

¹⁰ Quite apart from the possibility of reprojection discussed below, N-to-D-movement analyses have not gone uncontested, see, e.g., Bruening (2009; 2020: 33); Carstens (2017) for some references. For instance, some orders in the noun phrase may require movement of a constituent larger than a head, cf. Cinque (2005); Abels & Neeleman (2012). Bruening (2020) also refutes a recent argument for N-to-D-movement in Shona by Carstens (2017).

there is a DP-layer on top of NP. Such noun phrases could be smaller than DP, e.g., corresponding to nP or NumP, see, e.g., Danon (2006) for arguments to this effect for Hebrew construct state nominals. A more radical alternative involves reanalyzing (certain kinds of) head-movement in terms of reprojection where the moving head projects rather than the target, see Georgi & Müller (2010) and references cited there. The basic idea is that heads that undergo movement have a probe feature linked to a selectional feature that cannot be checked in-situ because the relevant constituent is a specifier and thus not c-commanded. In (28), N has the probe feature [**D**] requiring Agree with a DP under c-command. Reprojection is a last resort mechanism that moves the head to a position where it c-commands the relevant constituent, viz., D and thus can discharge its probe feature. Under this assumption, a DP-layer is no longer needed, NP is sufficient (see Georgi & Müller 2010: 19 for discussion of how to capture the dependency of N-reprojection on D being null):^{11,12,13}

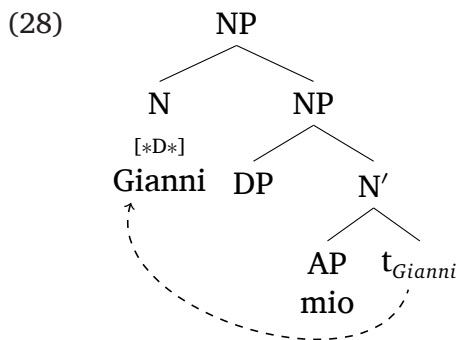

¹¹ Essentially the same argument can be made on the basis of binding relationships between postnominal arguments in English or German as in (i):

- (i) *German*
 der Bericht von jedem Studenten_i über seine_i Arbeit
 the report of every student about his work
 ‘every student_i’s report on his_i work’

To capture the c-command relationships one can assume that both arguments are projected within NP and that N undergoes reprojection afterwards, see Sternefeld (2006). Finally, the determiner is merged as a specifier of N.

¹² Reprojection in the verbal domain can also have the effect of making certain functional heads superfluous. See, e.g., Haider (2000) for an application to VP-shells, which eliminates vP, and Müller (2010a) for verb second movement in terms of reprojection, which eliminates CP (in verb-second clauses). Note, though, that such approaches do not claim that it is always the verb that is the head of the clause. This is restricted to V2-clauses, while verb-final clauses are still treated as CPs. Thus, an important asymmetry between the noun phrase and the clause remains.

¹³ Larson (to appear) cites preposition-determiner portmanteaus in languages like German or French as evidence for the DP-hypothesis. For instance, in French, *de* + *le* ‘of’ + ‘the’ yields *du*. However, at least for French, it seems well-established that this process is post-syntactic given that fusion depends on the shape of the determiner, i.e., it is blocked with cliticized determiners, cf., e.g., *de l’argent* ‘of the money’. Furthermore, the argument for head-status of D only goes through if the operation involved is Lowering. As discussed in Embick (2007: 328, fn.25), this is not fully clear since an intervening quantifier blocks fusion. The German facts cannot be used to argue in favor of D’s head status since amalgamations are also possible between the preposition and the determiner of a dative possessor in the specifier of a noun phrase, cf. van Riemsdijk (1998: 658–659). In (i), *zu* + *dem* can be contracted to *zum*.

- (i) *German*
 Ich sagte zu [_{DP} [_{DP} dem Hans] [_D seiner Frau]]
 I said to the.DAT John his wife
 ‘I said to John’s wife ...’

Clearly, the article involved in contraction is not the head of the noun phrase selected by the preposition.

2.5 Two remaining arguments

Before concluding this section, I will briefly mention two further arguments for the DP-hypothesis that do not fall into the categories above, viz., gerunds and asymmetries between languages with and those without articles. Both are interesting arguments but are either based on a poorly understood phenomenon (gerunds) or only constitute an indirect argument.

As for gerunds, Abney (1987: Chapter 3) proposes that gerunds involve a DP embedding a VP as in (29):

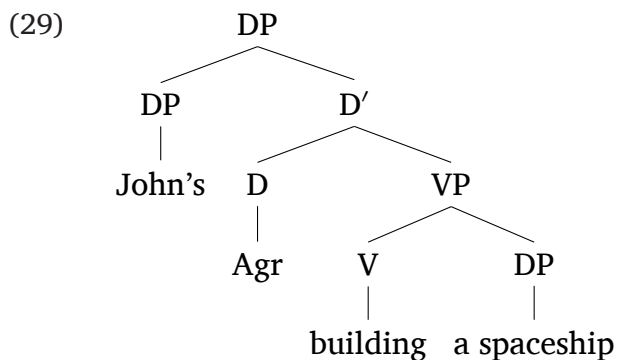

This captures both the verbal properties (accusative case, modification by adverbials) as well as the gerund's external distribution of a noun phrase. Furthermore, the absence of an N-layer accounts for the impossibility of adjectival modification. This would seem like an interesting argument for the DP-hypothesis since replacing D by a silent nominalizing N-head would probably predict – incorrectly – that modification by adjectives should be possible. However, many aspects of the phenomenon remain puzzling. First, Abney (1987: 197) presents examples from the older literature where gerunds do co-occur with adjectival modification. Ackema & Neeleman (2004: 176, fn. 27) suggest that parsing factors could be responsible for this change: once the gerund is encountered after an adjective, it is preferentially parsed as a noun; a following DP-object will require reanalysis. Second, if D is the head of gerunds, it is somewhat surprising that determiners are impossible, at least in English gerunds. Third, mixed nominalizations in other languages, e.g., in Dutch or German, are not subject to this modification restriction. Both an adjective or an adverb are possible, suggesting that nominalization can take place at different levels; note that Ackema & Neeleman (2004: 172–182) explicitly argue in favor of a silent nominalization affix in such constructions. See also Alexiadou et al. (2007: 477–546) for detailed discussion of the various proposals that have been advanced. Given these uncertainties, I prefer not to draw any conclusions from the gerund facts.

One of the most interesting though indirect argument for the DP-hypothesis comes from the work of Bošković (2009) on syntactic asymmetries between languages with articles and those without. He shows that the two types of languages differ in systematic ways from each other. For instance (the list is considerably longer), languages without articles allow left-branch extraction and extraction of adjuncts from NP, while languages with articles do not. The basic idea is that these asymmetries can be best accounted for if the languages have a significantly different noun phrase structure: Languages without overt articles have no D-layer whatsoever, i.e., noun phrases are NPs, while those in languages with articles are DPs. I find the basic logic of the argument convincing, even though it is not fully trivial to relate all the properties Bošković lists to D. However, in principle, it is also conceivable that the mere presence vs. absence of an element (viz., the article) has drastic syntactic consequences; this may hold irrespective of whether it is

a head (DP-hypothesis) or a specifier (NP-hypothesis). To make a concrete example, the ban against left-branch extraction in languages like English is related to anti-locality in Bošković (2005): An adjective that attempts to extract from DP has to move via SpecDP; however, this movement step is too local because it fails to cross a maximal projection (by assumption, the adjective starts out as an adjunct to NP and thus only crosses a segment of NP and D'). A reformulation under the NP-hypothesis does not seem impossible: Assuming, with Bošković (2016), that only the highest specifier of N constitutes an escape hatch, in a language like English, an adjective would have to move from a lower specifier of N to the highest one, above D-elements. This movement step could plausibly also be ruled out under a certain definition of anti-locality. In Serbo-Croatian, given the absence of definite articles, adjectives can be directly merged in the highest specifier of N and therefore are extractable. The crucial difference between English and Serbo-Croatian would thus not be the headedness of the DP but the presence vs. absence of D-related elements in the left periphery of the noun phrase. Needless to say, this should not be considered an attempt to reanalyze all the asymmetries discussed in Bošković (2009). But if they are to be reanalyzed within the NP-theory, the differences would have to follow from the presence of D-related elements rather than a difference in headedness. Because of such reservations and the fact that the approach does not directly tell us anything about the headedness of languages with D-elements, I will not discuss this perspective any further. See also Bruening et al. (2018: 37–38) for critical discussion; in Section 4.3 below, I will provide an argument that noun phrases in Serbo-Croatian are in fact DPs.¹⁴

¹⁴ The literature on the DP-hypothesis also contains arguments about hierarchy. For instance, the sentence in (i) only allows for certain interpretations in English:

- (i) Peter's picture of Mary

Peter must be interpreted as the possessor or the agent, while *Mary* is interpreted as the theme. The thematically higher argument thus occurs in a structurally higher position, which is reminiscent of the UTAH (Baker 1988). Related to this is the fact that only the highest thematic role within NP can appear in a special possessive form (with an -s ending or as a possessive pronoun). This also fits well with the observation that only the argument with the highest thematic role can be extracted from DP in Italian, cf. Coene & d'Hulst (2003: 23). If thematic prominence is mapped onto syntactic prominence, the thematically highest argument will also be structurally highest. As a consequence, extraction of thematically lower arguments will be blocked by Relativized Minimality. Further evidence for hierarchical organization comes from binding: It is always the agent/possessor that binds the theme and not vice versa:

- (ii) John_i's picture of himself_i

Of course, these facts all follow nicely if the agent occupies a specifier outside of NP such as nP (and moves from there to Spec,DP), while the theme occurs in a lower position as in (iia). However, they follow just as straightforwardly under the NP-hypothesis as long as the agent c-commands the theme, cf. (iib):

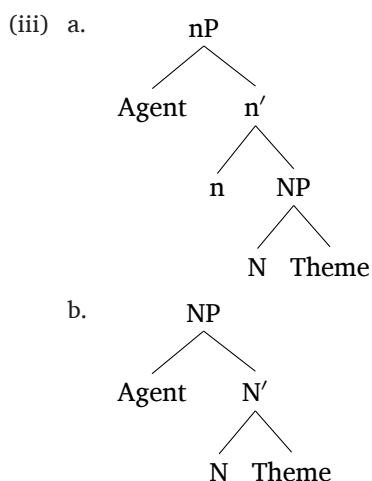

2.6 Intermediate summary

It should have become clear that the arguments in the literature in favor of the DP-hypothesis are not as strong as one would expect given its success in the last thirty years. All of the phenomena reviewed can arguably be handled under the NP-hypothesis as well. Since this will sometimes require somewhat non-standard assumptions that some syntacticians might reject, the DP-hypothesis may still be at a certain advantage, but as far as I can tell, none of the phenomena are such that they necessarily require the DP-hypothesis. Thus, the phenomena reviewed so far cannot in my view be used to decide between the NP- or the DP-hypothesis. Note also that none of the arguments surveyed so far actually refers to standard headedness criteria. I will address arguments of this type in Section four below and show that some of them do provide more insight into the headedness of the noun phrase.¹⁵

3 Arguments for the NP-hypothesis

In this section I will briefly take the reverse perspective and discuss arguments in favor of the NP-hypothesis. Such arguments are most prominent in Bruening (2009; 2020). Since his arguments relate to selection and form determination, they will be addressed separately in Section 4 below where I discuss the implications of standard criteria for headedness.

In this section, I will instead briefly discuss two possible arguments for the NP-hypothesis; one is based on an old observation, viz., stranding of D-related elements under noun incorporation, whose importance in the current discussion has been overlooked as far as I can tell. The second argument is based on the semantics of possessive pronouns (in German).

3.1 Noun incorporation

In noun incorporation D-related constituents like demonstratives, numerals and possessors can be stranded, see Baker (1988: 93–97). (30a) is the baseline example, (30b) illustrates stranding of a demonstrative, (31a–c) illustrate stranding of a relative clauses, a numeral and a possessor, respectively (the verb *rakv* ‘be white’ is unaccusative):

- (30) *Mohawk*
- a. Ka-rakv thikv ka-nuhs-a?
 3N-white DEM PRE-house-SUF
 ‘That house is white’
- b. Ka-nuhs-rakv thikv.
 3N-house-white DEM
 ‘That house is white.’
- (31) *Mohawk*
- a. Ka-nuhs-rakv [nehneh a-ak-ahninu].
 3N-house-white DEM INDF-3F-buy
 ‘The house that she would like to buy is white.’

Thus, such data only provide information about the relative c-command relationships within the noun phrase. They don’t tell us anything about headedness. A structure like (iia) is primarily motivated on the basis of parallelism with the verbal domain.

¹⁵ If one takes the NP-hypothesis to mean that N is the head and not some other element inside the noun phrase, viz. D, Num, Gen, one would have to show that the evidence that has been provided for these functional elements to be projecting heads can also be accommodated by means of the NP-structure. In fact, as far as I can tell, most of the evidence from the literature (see, e.g., Alexiadou et al. 2007: 227–255) is based on morphological facts and word order variation. The first type of argument is usually based on the assumption that the presence of morphological material implies the presence of a designated functional head hosting these features. Such a one-to-one relationship, however, is by no means a necessary assumption; note for instance that no designated projections are postulated anymore for agreement in the verbal domain. The word order evidence is of the type discussed in Section 2.4 above, usually based on partial N-movement, and thus equally inconclusive as data suggesting N-to-D-movement.

- b. Ka-**nuhs**-rakv [ne wisk ni-ka-wa].
 3N-house-white five PART-3N-PL
 ‘Five houses are white.’
- c. Hrao-**nuhs**-rakv [ne sawatis].
 3M-house-white John
 ‘John’s house is white.’

The structure of a noun incorporation example like (30b), which is usually assumed to involve head movement, looks as follows under the NP- and the DP-hypothesis, respectively (see Assmann et al. 2012 for a recent account based on the NP-hypothesis):

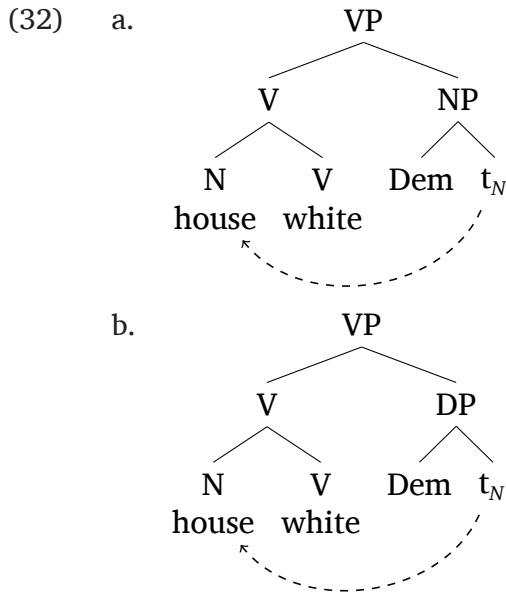

Under the DP-hypothesis in (32b), the head-movement constraint (Travis 1984) is violated as the D-head has been skipped. No problems obtain under the NP-hypothesis, where the demonstrative is located in a specifier of N. One possibility to uphold the DP-hypothesis is to assume that all overt D-related elements are specifiers of D and that noun incorporation involves N + a silent D (alternatively, N-to-D movement could be followed by excorperation of N, but excorperation is often ruled out on principled grounds, cf. Baker 1988):

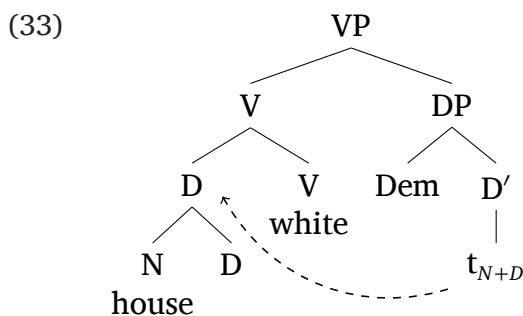

Such a reanalysis under the DP-hypothesis is not impossible, but at the same time it seems nearly impossible to falsify. What makes the stranding examples independently problematic is the fact that in the relevant languages, the putatively stranded elements are actually well-formed independent constituents that can occur outside noun incorporation contexts and can be roughly translated by means of NP-ellipsis, see Rosen (1989). Consequently, much more careful investigation of such ‘stranding’ cases is necessary before any conclusions can be

drawn, since the stranding argument is probably the strongest one for a syntactic approach to noun incorporation and against a lexicalist one (i.e., one involving compounding).

Note also that it has been argued that noun incorporation may involve incorporation of more than just the root. Barrie & Mathieu (2016: 27–31) observe that incorporated nouns often bear categorizer morphology and argue that noun incorporation therefore must involve phrasal movement rather than head-movement. I think it is fair to say that the proper analysis of noun incorporation is still very much a matter of debate.¹⁶

3.2 Possessive determiners

Müller (2007: 85–87) provides an argument for the NP-hypothesis on the basis of possessive determiners in German as in (34):

- (34) *German*
 seine Mutter
 his mother
 ‘his mother’

If the possessive determiner were the head of the noun phrase, Müller argues, we would expect the DP to carry its referential index and not that of the noun, contrary to fact. Since the possessive pronoun is visible for binding (cf. *his picture of himself*), one cannot simply identify its index with that of the noun; the problem is thus real. Müller therefore concludes that the possessive pronoun must be projected as a specifier of N. An alternative may consist in projecting the possessive determiner in SpecDP with D remaining empty. This would avoid projecting the wrong index up to DP.

The solution with a silent D will, however, no longer work once the possessor doubling construction is taken into account, which can be found in all German dialects and in Colloquial German. Here, the possessive pronoun is preceded by a dative possessor:

- (35) *German*
 dem Hans seine Mutter
 the.DAT John his mother
 ‘John’s mother’

In this construction the referential index of the possessor is arguably not borne by the possessive determiner but by the dative possessor, viz. *dem Hans*. Consequently, the possessive determiner can be analyzed as an agreement element as in languages like, e.g., Turkish which have systematic possessor agreement (in addition to dependent marking on the possessor; cf. also the examples from Yupik in (9) above):

- (36) *Turkish*
 Hasan-in kitab-in
 Hasan-GEN book-POSS.3SG
 ‘Hasan’s book’

For the version without an overt possessor in (34) above, one can assume that, as in languages like Turkish, there is a small *pro* in SpecDP. However, this is still not sufficient to ensure that the referential index of the noun is present on the maximal projection of

¹⁶ Essentially the same issue arises with extraction from noun phrases, which is only possible if verb and object form what is usually called a “natural predicate”. This relationship is often analyzed in terms of abstract incorporation of the noun into the governing verb; by removing the nominal barrier, the DP/PP can extract. This kind of analysis is only possible under the NP-hypothesis, while an intervening DP-shell would block incorporation. See Müller (2010b: 47–48) for discussion and references. The issue also relates to the principles of idiomatic interpretation discussed in Section 4.2.1.3 below.

the noun phrase if this is mediated via D. One possibility is to decompose the possessive determiner into a possessive and a D-part (cf. *sein-e* ‘POSS.3SG.M-F.SG’). The possessive part would be merged as a lower head within DP and then moved to D, which carries the referential index. The possessor could be initially merged in the specifier of the possessive determiner and then moved to Spec,DP.

Given these assumptions, possessive determiners are no longer problematic under the DP-hypothesis. Let me add, though, that the possessor doubling construction is, of course, certainly compatible with the NP-hypothesis. For more detailed discussion of these issues, see Georgi & Salzmann (2011).

4 Criteria for headedness and their implications for the NP/DP debate

In this last section I will establish what I take to be uncontroversial and largely theory-neutral diagnostics for headedness and explore their implications for the NP vs. DP debate. As we will see, since these criteria rely on very basic phrase structural properties, viz., projection and c-command/dominance, they allow rather clear predictions w.r.t. headedness. In what follows I will assume the following two fundamental properties of heads:

- the head and the complement are in an asymmetric relationship: the head selects the complement and can determine its features (case, morphological selection)
- the features of the head are present on the maximal projection

I take these properties to be uncontroversial and arguably shared by most contemporary syntacticians. They are thus largely theory-neutral. This is particularly clear for the first property, while the second property may be somewhat more debatable. As far as I can tell, it is presupposed in work within HPSG and work adopting Bare Phrase Structure but also regularly in work based on X-bar theory. More generally, the assumption seems necessary in all cases where phrases rather than heads are targeted for movement or where properties of a head rather than a specifier are accessed by an outside probe, i.e., in configurations where the A-over-A principle is at work. Opinions differ w.r.t. which types of features are present on the maximal projection. While inherent features of a head, e.g., the category label or the phi-features of a noun, are usually taken to be present on the maximal projection, this is less clear for operation-inducing features like probe- and structure-building features. They are sometimes taken to be present on the maximal projection, see Béjar & Řezáč (2009); Schoorlemmer (2009), while in other approaches it is crucial that they be present on the head only (see, e.g., Georgi & Müller 2010). Since in what follows only inherent features will play a role, such differences can be neglected and I will assume in what follows that the assumption that features of the head are present on its projections is well-established enough to base my arguments on it.

I will now explore the implications of these properties for the NP vs. DP-debate. I will first discuss arguments based on the head-complement asymmetry such as selection and form determination between D and N. As we will see, even though the DP-hypothesis can be shown to be at a slight advantage, these arguments will lead to a somewhat inconclusive result. Things are very different once phenomena are considered that are sensitive to the features on the maximal projection, viz., selection of noun phrases by verbs and agreement of hybrid nouns with noun-phrase external probes. These allow us to differentiate between the two hypotheses and clearly favor the DP-hypothesis.

4.1 Head-complement asymmetry

The head-complement asymmetry is manifested in two areas: Heads select their complements rather than vice versa and heads often determine properties of their complements. As we will see, while the prediction as such is clear, the result will be somewhat inconclusive for our debate.

4.1.1 Selection

Some D-elements like those in (37) require the presence of a noun:

(37) the, a

The reverse does not seem to hold as there are nouns that can occur without a determiner, e.g., bare plurals in English:

(38) books

This may suggest that D selects N and not vice versa. This reasoning presupposes that (38) does not contain a D-element. There is a long debate about whether bare noun phrases also contain a D-layer or at least some silent functional structure. I will briefly address this in Section 4.2.1.1 below. Here, I will limit the discussion to the consequences, once there is silent material such as a silent determiner in examples like (38). In that case, the asymmetry between D and N is no longer that obvious. Note also that singular nouns in English do require an article. Quite apart from the fact that it is not really obvious which element selects which, one has to make sure that the selectional requirement is really morphosyntactic and not purely semantic in nature. Note that there are categories that can only co-occur with constituents of a certain type, but this co-occurrence restriction is usually not thought of as selection. Adverbs are a case in point: They only attach to VPs, but they are usually not classified as syntactic heads taking the VP as their complement. W.r.t. the semantics, definite articles turn the noun, which is a predicate, into an expression of type $\langle e \rangle$, cf., e.g., Longobardi (1994). However, nothing in this semantic computation requires the determiner to be the head (cf. Bruening 2009: 31 for more discussion).

Importantly, though, Larson (to appear) points out that semantic selection will not be sufficient to account for the distribution of determiners since they are not compatible with just any predicate. Rather, they only combine with nominal predicates but not with adjectival predicates:

(39) Every man/happiness/*happy

Under the NP-hypothesis, one has to assume that N can select D, while A cannot. The DP-hypothesis is at an advantage here in that one selectional statement is sufficient: D selects nominals.¹⁷

¹⁷ Bruening et al. (2018) argue that D can select N even under the NP-hypothesis. This implies that non-heads can select, too. They argue that this is independently necessary for adjectives, which select NPs, and adverbs, which select VPs. I am not convinced that these adjuncts really syntactically select their complement. Adjectives seem to combine with predicates more generally, e.g., also with verbs under complex predicate formation as in resultatives, and the position of adverbs is arguably restricted by the semantics of the verbal constituent they attach to, see Ernst (2002).

Larson (to appear) provides another argument for the head status of determiners, viz., the fact that some of them select partitive PPs:

- (i) a. Both/some/no men
- b. Both/some/*no of the men

However, the generalization seems to be different. The determiners that are compatible with partitive PPs are those that can appear without an NP-complement. Under the assumption that this indicates NP-ellipsis, this suggests that it is N rather than D that selects the partitive phrase. This seems to be the case more generally (cf. *two bottles of wine*), although I must admit that it is not clear to me what content the silent NPs would have in (ib), perhaps *men*.

4.1.2 Form determination

It is well-established that heads determine the form of their complements. This can be seen in case marking and morphological selection. With respect to morphological selection between verbs (also referred to as status government), it is generally the case that V_n determines the form of V_{n+1} , i.e., the governing verb determines the form of the immediately dependent element, as, e.g., in (40) (from Bruening 2009: 30):

(40) I might have been being handed some cocaine (when the police caught me).

Furthermore, it is usually the functional (auxiliary, modal, restructuring) verb that determines the lexical verb rather than the other way around (a possible exception being auxiliary selection, but the choice of auxiliary is often determined by several elements, including, e.g., directional PPs, not just the lexical verb):

(41) I broke/was breaking/have broken/want to break the vase.

Bruening (2009) argues that there are asymmetries within the noun phrase suggesting that N is the head rather than D. Indeed, when we look at nominals the reverse situation seems to obtain: It is the noun that determines the form of other constituents inside the noun phrase. For instance, the count/mass distinction affects the choice of modifiers, cf. (42):

(42) a. too many/*much people
b. too much/*many rice

While this may not constitute proper agreement but rather represent some semantic compatibility requirement based on the count/mass distinction, concord within the noun phrase is a clear case where the form of determiners and adjectives depends on features of the noun. This holds at least for those features that are inherent to the noun; this can be number as in the case of pluralia tantum, cf. (43a) or gender, cf. (43b):^{18,19}

(43) a. these/*this scissors
b. *Latin*
puer bon-us/ puella bon-a
boy.M good-M girl.F good-F
'good boy/good girl'

¹⁸ Obviously, this argument only works if one allows N to have some features.

There does not seem to be an equivalent of something like pluralia tantum in the verbal domain, i.e., a verb that can only be specified for a certain feature value. There are cases where a certain verb does not occur in all tenses or is incompatible with finite/non-finite morphology (e.g., the German raising verb 'seem', which only occurs as finite), or, as in the case of Latin deponent verbs, only with passive morphology (cf. Embick 2000). However, these cases are probably better described as paradigmatic gaps. At any rate, there is clearly no covariation w.r.t. these properties.

¹⁹ There is one systematic exception, viz., definiteness agreement: Definiteness is generally taken to be a property of D, but in some languages there is also a definiteness exponent on N, as, e.g., in Swedish:

(i) *Swedish*
det stor-a hus-et
DEF big-WEAK house-DEF
'the big house'

However, it seems to be well-established that definiteness agreement between D and N works differently than normal concord, see, e.g., Embick & Noyer (2001) or Schoorlemmer (2012) for discussion. See also below for discussion of how definiteness affects the inflection of adjectives in some languages.

The argument from concord is interesting, but it must be pointed out that it is crucially different from morphological selection or Case assignment: It involves the copying/sharing of (inherent) features rather than the assignment of features to other constituents that the head/governor itself does not bear. Note, for instance, that a verb that assigns accusative is not accusative itself, i.e., there is no morpheme that would identify it as an accusative assigning element. If there were feature sharing, one might expect verbs to have special morphology depending on the case they assign, but that is not what one finds. Similarly, verbs that select a certain type of infinitive do not have any morphological property that would signal this (they may belong to a different class, e.g., restructuring vs. modal, but that is orthogonal). In concord, the noun will usually have a morphological exponent that expresses the feature, e.g., the plural-*s* ending above.

I conclude from this that the relationship between D and N is crucially different from that between the verbs in the sentence in (40) above. Therefore, in my view the concord data do not provide any conclusive evidence that N is the head rather than D.²⁰

Another possible argument on the basis of form determination can be made by means of adjectival inflection, which in Germanic languages is affected by the choice of D. I will illustrate the argument on the basis of German, where attributive adjectives display so-called strong and weak inflection. Synchronically, this inflection is not related to definiteness (unlike in some of the other Germanic languages). Rather, the inflection is determined by the form of the determiner. Simplifying somewhat, a zero determiner or a determiner without an ending selects the strong inflection, while a determiner with an ending selects the weak inflection:

- (44) *German*
- a. (ein) rot-er Wein
a red-STR wine
'a red wine'
 - b. ein-em rot-en Wein
a-DAT red-WK wine
'to a red wine'
 - c. rot-em Wein
red-STR wine
'to red wine'

This clearly suggests that D is the head relative to material in its c-command domain. The dependency can be captured straightforwardly under the DP-hypothesis, where the determiner will be a head that c-commands the adjective. This represents a standard configuration for Agree. Under the NP-hypothesis, where the determiner occupies Spec,NP, one will have to assume that phrasal elements can as probes (under Bare Phrase Structure,

²⁰ Note that both morphological selection and concord have received relatively similar analyses, viz., analyses in terms of Agree. But it is not clear to me that this justifies treating the phenomena as essentially the same. For morphological selection, upward Agree, viz., downward valuation, is the obvious choice, cf. Wurmbrand (2012). Here, the unvalued feature is on the lower element and the value is provided by the higher element. With concord, the valued features are on N and the unvalued ones are on the modifiers D and A. This will imply downward Agree/upward valuation under the DP-hypothesis, cf. Danon (2011), and even under the NP-hypothesis, this could be treated as such (if the features of N do not project). An alternative under the NP-hypothesis would be that concord involves feature checking under sisterhood, i.e., between A and N and D and N' (assuming that the features of N project). This would make it more similar to morphological selection, but there remains a crucial difference: In morphological selection, this would always involve relationships between a head with the valued feature and its sister; in concord, this would often involve a sisterhood relationship where the valued feature is on a projection of the head (as in Agree between A and N').

the determiner would be [+max, +min]). We thus obtain the structures in (45a) and (45b) (of course, under Bare Phrase Structure, the adjectival modifier would be merged as a complement under the NP-hypothesis):

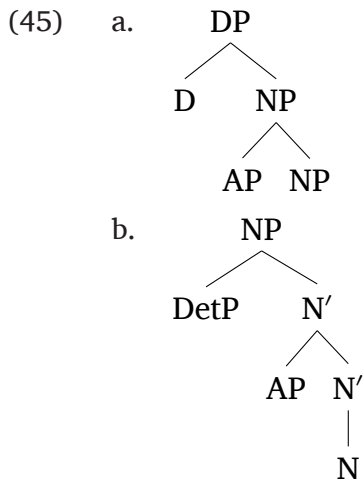

The force of this argument to some extent depends on how concord on adjectives is handled. If they are adjoined as in (45a) and attributive adjectives probe for features of N, the probe will be on a non-head. The configuration would thus be very similar to that in (45b), where the probe determining adjectival inflection is also on a non-head, viz., the determiner. Thus, the argument from adjectival inflection only works if we assume that form determination is crucially different from concord, viz., that only projecting heads can determine the form of other elements (as is the case in the verbal domain, recall example (40)). Finally, since D does not interact with N, the phenomenon strictly speaking does not tell us anything directly about the relationship between D and N; but given that D displays head-like behavior w.r.t. form determination, it may be considered an indirect argument in favor of its being the head of the noun phrase.²¹

4.2 The features of the head are present on the maximal projection

This fundamental property of heads has the consequence that it is the features of the head that are visible to the syntactic context outside the noun phrase. Features of other noun phrase-internal constituents, on the other hand, are much less accessible.

This can have the following (well-known) syntactic effects: First, the head determines the distribution of the phrase because its category label is visible on the projection. Second, the head is the preferred element for higher heads to interact with. This is seen in the fact that the head/features of the head are the preferred target for selection and agreement. Furthermore, given the A-over-A principle, the features of the head will be closer to probes outside the noun phrase and can therefore potentially block interaction of outside probes with constituents inside the noun phrase.

²¹ Note that it is far from clear that a syntactic analysis is the right solution to this phenomenon in German because the interaction crucially depends on the surface form of the determiner rather than particular morphosyntactic features. See Sternefeld (2004) for an approach based on pre-syntactic morphology.

A similar argument for D as the head can be made based on the genitive of quantification that is found in Slavic languages: The NP in the scope of the numeral/quantifier appears in the genitive, suggesting that it is the numeral/quantifier that is the head of the noun phrase. Note that in the analysis in Bošković (2006) the quantifier is in fact located in the specifier of a functional head, which assigns the genitive. It is a rather small step from such an analysis to one where the quantifier is located in SpecNP and assigns the genitive itself. Again, all depends on whether we want to restrict form determination to projecting heads.

We have already discussed the distribution argument in Section 2.1.2 above and came to the conclusion that no compelling argument could be made for either the NP- or the DP-hypothesis. In the following (sub)sections, I will discuss possible evidence based on selection and agreement that capitalizes on the fact that the preferred target for noun-phrase external probes is the (features of the) head.

4.2.1 Selectional relationships between the verb and the noun phrase

I will discuss three aspects of selection in this subsection. First, I will discuss categorial selection and focus on the question whether verbs can select noun phrases of different categories. Second, I will investigate whether verbs ever select particular phi- or definiteness features of noun phrases. Third, I will discuss an argument by Bruening et al. (2018); Bruening (2020) based on idioms suggesting that the verb actually selects N rather than D.

4.2.1.1 Categorial selection

Bruening et al. (2018: 6) argue that selection of nominal complements is crucially different from selection of verbal complements: It is well-established that verbs can select verbal complements of different sizes, viz., CPs, TPs, vPs and VPs. However, the equivalent does not seem to exist in the nominal domain. According to the authors, there are no cases where a verb selects just a NumP or an NP. However, as Larson (to appear) points out, there is a crucial difference between selection of verbal vs. nominal complements: Verbal complements of different sizes are all propositional. Nominal complements, however, are either of type $\langle e \rangle$ (definite noun phrases) or type $\langle \langle e, t \rangle t \rangle$ (quantified phrases). Selection of NP is simply not possible because they are of the wrong type, viz., $\langle e, t \rangle$ (unless type-shift is a possibility, see below). Thus, the semantic types severely limit the variability w.r.t. categorial selection of noun phrases.

Before giving up on this potential argument, it is worth taking into account the possibility that not all noun phrases within one language are of the same size. In many languages, also in English, we find noun phrases such as bare plurals without visible determiner in argument position, even though noun phrases otherwise do have an overt definite or indefinite determiner in the language. The question is what this implies for the NP- vs. DP-debate. There are basically two analytical possibilities for bare nouns. Either, there is silent material or not. Under the DP-hypothesis, this will imply that the noun phrase is either a DP (with a silent D) or just an NP. Under the NP-hypothesis, it will be an NP in both cases, but either with a silent D in its specifier or without.

- (46) DP-hypothesis
 a. $[_{DP} \bar{\exists} [_{NP} N]]$
 b. $[_{NP} N]$

- (47) NP-hypothesis
 a. $[_{NP} \bar{\exists} [_{N'} N]]$
 b. $[_{NP} N]$

Suppose for the sake of the argument that the second solution without silent material is correct; see Jenks (2018) for a recent argument that definite bare nouns in Mandarin are just NPs that are type-shifted before they combine with verbs, while definite noun phrases headed by demonstratives are DPs.

Importantly, the fact that verbs can co-occur with different types of noun phrases as such has no implications for the NP- vs. DP-debate, perhaps apart from the fact that selection would be more consistent under the NP-hypothesis (but recall from 2.1.2 above that

this argument is not very strong anyway). The crucial point is that (probably) all verbs of the language can occur with both definite or indefinite noun phrases. Thus, selection of NP or DP would not have to be stated in each lexical entry.

Things are different with pseudoincorporation. It is frequently assumed that pseudo-incorporated nouns are just NPs that are predicates semantically and thus compose differently with the verb than noun phrases denoting individuals, cf., e.g., Massam (2001). Contrary to the claims in Bruening et al. (2018); Bruening (2020), it is not the case that each verb of a language can occur with both ‘regular’ and pseudo-incorporated nouns. As was pointed out to me by one of the anonymous reviewers, the class of verbs that allows pseudo-incorporation is always restricted. For instance, as discussed in Kallulli (1999), in Albanian, a language that generally allows bare count singulars, pseudo-incorporation is blocked with individual-level predicates like ‘love’, ‘hate’, ‘admire’, ‘respect’. Furthermore, it is often observed that verb and noun together express an ‘institutionalized activity’, see Dayal (2011: 164–165). There is thus clearly a selectional component. Under the DP-hypothesis, one can state that some verbs allow the selection of NPs in addition to DPs. Under the NP-hypothesis, the difference can arguably only be captured by means of semantic selection, viz., some verbs can select predicates in addition to individuals. The DP-hypothesis thus seems to be at an advantage. Note that pseudo-incorporation sometimes has a tendency towards non-compositional/idiomatic interpretations, which is why I will come back to it in Section 4.2.1.3 below. Weak definites present a problem similar to pseudo-incorporation and will be addressed in the same subsection.

Most relevant for the current debate would be predicates that are only compatible with a certain type of noun phrase, e.g., only an NP, nP or NumP but not DP. This would be straightforward to state under the DP-hypothesis, while under the NP-hypothesis, it is unclear how this could be done (one cannot select the absence of structure, see below). Crucially, the selectional relationship would have to be morphosyntactic rather than semantic. Claims that certain verbs/predicates can syntactically select noun phrases of different size are somewhat hard to find. In a recent squib, Erschler (2019) argues for a particular comitative preposition in Ossetic languages that it selects a NumP and is crucially incompatible with DP. He observes that it is not compatible with definite noun phrases (pronouns, proper names, demonstratives). To appreciate this argument, it is important to note that a synonymous comitative case-marker is not subject to this restriction. Furthermore, he stresses that this is not semantic selection: While the preposition is generally compatible with indefinites, it cannot combine with indefinites that take a definite or indefinite possessor, which he relates to the fact that possessors move to Spec,DP and thus imply the presence of a D-layer. This is a very interesting argument and it could indeed be used as an indirect argument for the DP-hypothesis, where the selection of nominals of different sizes is an obvious possibility. Under the NP-hypothesis, it is not clear how the restriction of this preposition could be stated. One could assume that P selects an N which in turn selects Num, but this would not suffice to prevent merger of a D-element; it is not obviously possible to select a category which in turn selects the absence of something. Any attempt to formulate something like that would rather show that the analysis is misguided and fails to capture a simple generalization.

Other arguments of this type are scarce. Erschler (2019) cites a few other potential cases. Pereltsvaig (2006) argues that in Russian an aspectual prefix selects QPs rather than DPs, but as argued in Bruening et al. (2018: 6, fn. 6), it is not clear that this type of selection cannot be semantic in nature. Given the relative scarcity of data requiring the selection of noun phrases of a smaller size, the situation is not fully conclusive at this

point, but categorial selection is one area that can, in principle, distinguish between the DP- and the NP-hypothesis. Given the discussion in this subsection, it seems to me that the DP-hypothesis is at an advantage since it can more readily accommodate the selection of noun phrases of smaller size.²²

4.2.1.2 Selecting features of D vs. N

It is normally assumed that C-selection and morphological selection target the head of the selector's complement. In line with this, verbs that take clausal complements select properties of those complements that are usually associated with the highest head of that complement (C if finite or +/– wh, +/– V2, +/– subjunctive; T if non-finite etc.). Some of the verbal selection may be semantic (+/– wh), but especially the cross-linguistic variation w.r.t. the finiteness of complements of verbs and whether the non-finite clause occurs as a *to*-infinitive or as a bare infinitive (cf. English *want* vs. German *wollen*) suggests that not all selection can be reduced to semantics.²³

Bruening (2009) argues that the selection of noun phrase-related properties favors the NP-hypothesis. Indeed, when we look at noun phrases, it seems that verbs never select noun phrases with particular D-related properties such as specific determiners, determiners with a particular definiteness value (but see Section 4.2.1.3 below), or with an obligatory possessor. For instance, one does not find verbs that can select an NP without a possessor but not one with a possessor:

- (48) nonexistent pattern:
 a. John glorped books.
 b. *John glorped his books. Bruening (2009: 28)

There is thus little evidence that verbs select D-related properties when they combine with noun phrases (see Abney 1987: 86–87 for suppletive verbs in Navaho that are sensitive to number or class of the object, but that should probably not be treated as a case of selection). This does not support the DP-hypothesis; but for selection to represent an argument for the NP-hypothesis, we would have to find evidence that verbs select properties of N. Selection by the verb can target certain properties of N, e.g., whether it is animate/inanimate, but this is generally taken to be purely semantic selection. A clear case of syntactic selection would involve morphosyntactic features of N such as [gender] and [number], but such selectional dependencies have not been documented to my knowledge. The following examples show that cases of apparent number selection are only semantic: The verb *meet* selects a noun phrase that is *semantically* plural, not one that is syntactically plural (see Larson to appear for arguments that semantic selection cannot decide the NP-vs-DP-debate).

- (49) a. The students met.
 b. *A student met.
 c. The French club met.

²² Selection in existential constructions may be of this type. As argued in Kallulli (2008), *there*-existentials require a NumP (as in existential bare plurals) rather than an NP (existentials are not compatible with count bare singulars) or a DP (they are not compatible with definite noun phrases). Kallulli relates the restriction to the subject's being merged as the subject of a small clause structure (where NPs are not possible). As the analysis shows, though, this is not selection by an individual verb.

²³ It must be added, though, that there are also cases of selection where the verb alone does not determine the form of its clausal complement; for instance, sometimes negation or a yes-no-question in the matrix clause makes a + wh-complement possible that otherwise cannot occur with a particular predicate, cf., e.g., *sicher* 'sure' in German.

The result is thus inconclusive in my view. While there is solid evidence that verbs select clausal complements of certain kinds, there is generally rather little evidence that they can select noun phrases of a particular type. The properties of noun phrases they select are neither morphosyntactic properties of D nor of N. Why this should be the case is actually somewhat puzzling, but for reasons of space I will not pursue this question any further. Note that selection of specific determiners does occur with certain collocations and weak definites, which is why they are addressed in the next subsection.²⁴

4.2.1.3 Idioms

Bruening et al. (2018) and Bruening (2020) discuss selection relationships in conventionalized expressions. They show that these expressions always consist of (potentially a sequence of) local relations, roughly government relations between heads. There can be open slots, but they never affect heads in the government sequence but only left branches or the lowest complement; for instance, while there are idioms involving V + P + N, there are no idioms involving just V + N with P being completely open. Interestingly, there emerges an interesting asymmetry between the verbal and the nominal domain. While conventionalized expressions can involve verbs selecting functional heads with particular properties, e.g. + wh-clauses or particular prepositions, there do not seem to be conventionalized expressions involving nominals where the D-position is fixed, according to the authors. Even if there is a default specification for the D (e.g., *the* or *a* or no determiner at all), they argue that the choice of D can always vary. What cannot vary, however, is the content of N. This strongly suggests that N + V form a closer unit than N and D and thus favors the NP-hypothesis.

There are two aspects that need to be discussed separately. The asymmetry between C and D and the empirical facts about D-flexibility. As for the first issue, it is not quite clear to me what the comparison between D and C tells us. According to Bruening (2020), C is always fixed, while D is not. Perhaps there are independent reasons for this: The variation in the D-position usually achieves a certain semantic effect in that it affects the uniqueness of the event (cf. *foot the bill* vs. *foot another bill*). It is not clear to me that something similar would be possible if the C-position were flexible: After all, once a verb selects a + wh complement, this will affect the entire syntax, e.g., trigger wh-movement, inversion etc. and lead to a certain semantics. It is hard to imagine that there could be a conventionalized expression with flexible C-selection that would still have roughly the same meaning in both uses (i.e. one + wh and one –wh) or where the variation would achieve an effect similar to what we find with noun phrases. Thus, while there clearly seems to be an asymmetry, it is not clear whether it tells us anything about selection.

As for the second issue, the claim that the D-position is always flexible, Larson (to appear) takes issue with this argument in favor of the NP-hypothesis. He points out that in many cases there is a default specification for D in verb-object idioms. One does find deviations from the default specification, but Larson argues that this is creative language use that is generally possible with idioms and not indicative of an open slot. The different Ds used in such contexts are reconstrued as adverbs that quantify over the event rather than the noun. He provides variations on *bring down the house* such as *some houses*, *most houses* etc. Larson goes on to argue that the fact that there is a default specification for D is thus rather unexpected under the assumptions in Bruening (2020), who will thus need selection after all to account for that (i.e., V selects an N which in turn selects a D). He

²⁴ Larson (to appear) argues that at the level of logical form, verbs only combine with definite DPs: either definite DPs, proper names and pronouns that remain in-situ at LF and quantified nominals that undergo QR and leave a definite trace behind. He thus concludes that verbs do select properties of D.

also points out that the determiners cannot be motivated semantically in idioms since they don't have the same function as in normal noun phrases; for instance, a definite determiner does not turn a predicate into a referring expression. But once selection of D is needed after all, the argument for the NP-hypothesis collapses, according to Larson.

I think Larson does have a point, and I wonder whether one can find counterexamples to the claim that D is always flexible. In German, impressionistically, many conventionalized expressions seem similar to English in that there is usually a default specification for the determiner, but one will probably find some flexibility in corpora. However, there are collocations roughly equivalent to 'pay attention to' (so called *Funktionsverbgefüge*) that are clearly not flexible. Sometimes, a specific determiner is obligatory as in *zur Anklage bringen*, literally 'to accusation bring' = 'accuse'.²⁵ Sometimes, the absence of a determiner is obligatory, e.g., with *in Kraft setzen*, literally 'in force put' = 'put into effect'. These two collocations do not seem to allow any modification whatsoever (as verified by means of a corpus search in the COSMAS II corpus, cf. <https://cosmas2.ids-mannheim.de/cosmas2-web/>), although some of these collocations marginally allow modification by means of adjectives. This does not hold for all collocations of this type, cf., e.g., *Entscheidung treffen* 'decision meet' = 'decide', where the determiner is flexible and modification is possible. But at least w.r.t. the type/presence/absence of a determiner, there does not seem to be any flexibility with many of these collocations, especially with those involving a preposition.

Another relevant area are weak definites as in, e.g., *read the newspaper, take to the hospital, take the X (e.g., bus), play the X (e.g., piano)*. These expressions differ from regular definite noun phrases, e.g., in that they do not seem to exhibit uniqueness effects (they allow covarying interpretations under quantification and ellipsis), take narrow scope and in that they do not support anaphora, see Aguilar-Guevara (2014: 185–186). What is crucial for our purposes is that pseudoincorporated structures in the very same languages seem to have the same properties as weak definites, see Aguilar-Guevara (2014: 192–193). Thus, while there is a definite determiner in the examples above, there are also expressions like *send to jail, stay in bed, be in prison, go to school, watch television, have breakfast/lunch/dinner*. There is usually complementary distribution w.r.t. the determiner in that there either is a definite determiner or a bare noun but no optionality. Similar facts hold for other languages. In German, for instance, one has to say *den Bus nehmen* 'take the bus' but *Klavier spielen* 'play piano'. In the latter case, a bare noun is obligatory, while in the corresponding English expression a definite article is necessary. The reverse can also be found: While English uses a bare noun in *stay in bed*, German requires the definite article, cf. (with P + D-contraction) *im Bett bleiben*.

There is a line of research that treats the definite article in weak definites nevertheless as a regular definite article and derives the semantic differences by other means, see, e.g., Schwarz (2014). The question then is what this implies for the expressions with bare nouns. One could postulate a silent determiner with the same semantics as the one in weak definites. Selection would then be consistent and in both cases one would need to type-shift the definite DP to a property. Alternatively, only weak definites are DPs, while bare nouns are NPs. In that case, type-shift could be limited to weak definites. A third possibility is that the determiner does not mean anything in these expressions, i.e., it is as meaningless as in opaque idioms like *kick the bucket*. Both weak definites and bare noun constructions would then be treated as collocations with arbitrary specifications for the determiner. Since both weak definites and bare noun constructions are restricted to

²⁵ Note that the example involves obligatory preposition-determiner contraction and is based on the definite determiner. Contraction is obligatory with all collocations of this type that involve a preposition.

certain (types of) verbs and nouns, describe what is often called a stereotypical activity and sometimes have non-compositional meaning (cf. German *Fuss fassen*, lit. ‘catch foot’ = ‘gain ground’), the link to idioms is obvious. For my purposes, it is arguably irrelevant which of these three solutions is adopted. What seems clear is that syntactic selection is involved: As a native speaker, we know which expressions require a definite article and which require a bare noun/silent determiner. Since the constructions have the same meaning, the differences w.r.t. the presence of the determiner cannot be accounted for semantically.²⁶

Thus, while determiners may often be flexible in idioms, there are conventionalized expressions both in English and other languages where there is no flexibility at all and selection of D-elements is thus indispensable. This clearly favors the DP-hypothesis since one can directly refer to properties of D (or, in the case of bare nouns, select just an NP). Under the NP-hypothesis, one would have to have selection of Ns that in turn select a particular kind of D, which is doable, though not particularly elegant. Much more problematic for Bruening et al. (2018) are the cases where no D-element is allowed since nothing in their system precludes adding an optional modifier to N (one cannot select something that selects for nothing). In conclusion, upon closer inspection, the evidence from conventionalized expressions actually favors the DP-hypothesis.²⁷

4.2.2 Agreement asymmetries and intervention

Given that the features of the head of the noun phrase are present on the maximal projection, we expect the (features of the) head to be the preferred goal for probes outside the noun phrase.

Suppose that a functional head such as v/T targets the noun phrase for subject/object agreement. One expects it to preferably target (features of) the head because that constitutes the closest goal. Furthermore, the head may block access to features of lower heads; this may be related to phasehood if the highest head of the noun phrase is a phase head or more generally to Relativized Minimality since the head of XP c-commands/the XP dominates (A-over-A-principle, cf. Chomsky 1973) lower heads/projections. The two different analyses of the noun phrase make crucially different predictions in this respect: Under the DP-hypothesis features of N may be inaccessible, while under the NP-hypothesis, things would be expected to be the other way around: Features of D may be inaccessible (material that may be inaccessible is set in gray):

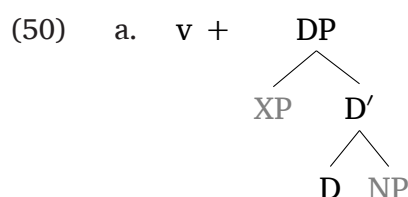

²⁶ The use of the definite article in weak definites can probably be motivated diachronically, e.g., at some point, these expressions were indeed unique in a certain context/situation, e.g., at a time when there was just one newspaper in town. In German, if one goes to an Italian restaurant, one says *zum Italiener gehen*, lit., ‘go to the Italian’; one can imagine this expression going back to a time when there was just one Italian restaurant in town. It is conceivable that weak definites develop into bare noun constructions over time when the motivation for the definite article becomes increasingly weaker (i.e., once the uniqueness criterion is no longer satisfied); but I do not know if this can be substantiated with precise corpus data. What is crucial for present purposes is that the synchronic distribution is at least to some extent idiosyncratic, making a syntactic selection account necessary.

²⁷ Bruening et al. (2018) still have a point in that the absence of idioms involving only V + D with N being flexible is unexpected under the DP-hypothesis. There is some flexibility in some weak definite constructions, e.g., with *play*, *take*, but the object is limited to a certain type (instrument, means of transport). I have to leave more detailed discussion of this for future research.

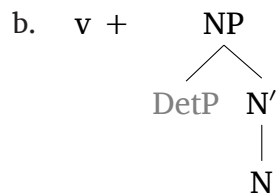

In the argument to be presented below, noun phrase-internal concord will play an important role. For this we need to make certain assumptions about the locations of features within the noun phrase. What follows is a certain simplification because for each of the relevant features within the noun phrase it has been proposed that they reside in separate functional heads (see, e.g., Danon 2011 for discussion). For my purposes, the following simplification will not cause any problems: I will assume that both gender and number are inherent features of N, while person and definiteness are features of D (recall that a comparison of the DP-hypothesis with the NP-hypothesis is only possible if at least some features originate on N). When a verb shows agreement with features of the noun phrase that originate from different noun-phrase-internal heads, there are two main analytical possibilities: Either the head (v/T) can probe several times and target different heads of the noun phrase or the head (N or D) ‘collects’ the features; consequently, it is sufficient for v/T to target only the head of the noun phrase and copy everything from there. In the derivations below, I will assume that determiners, demonstratives, adjectives (and possibly other noun-phrase internal constituents) bear probe features and that the head collects the relevant features.²⁸

4.3 Hybrid agreement

We now turn to the empirical argument in favor of the DP-hypothesis. It is based on agreement with hybrid nouns in BCS (Bosnian-Croatian-Serbian), more specifically, on the possible switches between grammatical and semantic agreement within the same clause. The facts will show that the features of demonstratives are more accessible to outside probes than the features of N. This strongly suggests that N is not the head.

In many languages agreement can target both grammatical as well as semantic features of nouns. For instance, in English, the verb can show plural agreement with collective nouns like *committee* that denote a plurality. In the data to be discussed below the relevant feature is gender. Nouns denoting human entities often have grammatical gender features that diverge from their natural/biological/semantic gender. Most interesting are so-called hybrid nouns that can in principle agree both in semantic and in grammatical gender. Even more interesting is the fact that in some languages, different probes within the same clause (e.g., D vs. v/T) can access different types of features of the noun, i.e., some may target the grammatical and some the semantic feature. Interestingly, both semantic agreement as such cross-linguistically as well as hybrid agreement within the same clause (i.e., different probes targeting either grammatical or semantic gender features of the noun) are governed by a hierarchy:

²⁸ Cowper (1987) presents an argument for the DP-hypothesis based on pied-piping. As is well-known, pied-piping in English wh-movement cannot involve nouns that govern PPs containing the wh-phrase like **I wonder the picture of whom John likes*. Since the features $+/-wh$ that are relevant for pied-piping are features of D and not N, blocking percolation of the wh-feature to the upper NP is difficult if N is the head. However, if the D *the*, which is $[-wh]$, is the head, percolation of the $[+wh]$ feature can be straightforwardly blocked. To account for pied-piping by wh-specifiers like *whose*, one has to assume that the wh-word in Spec,DP and D agree in wh-features. Needless to say, given the many intricacies surrounding pied-piping, the force of this argument may be limited.

- (51) The Agreement Hierarchy:
 ATTRIBUTIVE > PREDICATE > RELATIVE PRONOUN > PERSONAL PRONOUN
 ‘the possibility of syntactic agreement decreases monotonically from left to right. The further left the element on the hierarchy, the more likely syntactic agreement is to occur, the further right, the more likely semantic agreement (that is, with no intervening decrease).’ Corbett (2006: 207)

Relevant in the present context are the effects of the hierarchy in the same clause: It allows for agreement switches from grammatical to semantic agreement. Languages can have different cut-off points where they switch from grammatical to semantic agreement, and the cut-off point may be flexible even within a given language. For instance, languages can also switch within the attributive domain, viz., between A and D or even between different adjectives. Importantly, once there has been a switch to semantic agreement in a sentence, one cannot switch back to grammatical agreement, as schematically shown in (52) (A2 is a lower, A1 a higher adjective, V is the participle used in compound tenses; || indicates an agreement switch):

- (52) a. A2:gramm – A1:gramm – D:gramm || V:sem
 b. A2:gramm – A1:gramm || D:sem – V:sem
 c. A2:gramm || A1:sem – D:sem – V:sem
 d. *A2:gramm – A1:gramm || D:sem || V:gramm

The following example from BCS involves the noun *vladika* ‘bishop’, which is grammatically feminine, but its semantic gender is masculine. We observe a (optional) switch between D and V as in (52a) (Puškar 2018: 304):

- (53) BCS
 On-e vladik-e su me jučce posetil-e/posetil-i.
 those-F.PL bishop-PL are me yesterday visit.PTCP-F.PL/M.PL
 ‘Those bishops visited me yesterday.’

An example from BCS with a switch between A and D (52b/d) is given in (54) (Zorica Puškar, p.c; see Corbett 2006: 206 for a similar example).

- (54) BCS
 On-i star-e vladike su se posvadjal-i/*posvadjal-e na ulici.
 those-M.PL old-F.PL bishops are REFL argued-M.PL/argued-F.PL on street
 ‘Those old bishops argued on the street.’

It should be pointed out that there appears to be some speaker variation w.r.t. the possible switches and cut-off points, especially within the noun phrase; for instance, BCS does not seem to readily allow a switch between different adjectives, while Russian does, see Pesetsky (2013: 37–38). What is sufficient for our purposes, though, is that D can agree in either feature.

Note that the effects of the agreement hierarchy are not restricted to gender. They are also found with number, as discussed for Lebanese Arabic in Pesetsky (2013: 45–49), and for Hebrew in Landau (2016). In what follows, I will base the argument on gender, but nothing really hinges on this. I will adapt the analysis proposed in Puškar (2017; 2018) to my present concerns (this will be a significant simplification in many details and cannot do justice to the many aspects addressed in Puškar’s work). Let me stress at this point that there are, of course, different ways of distributing phi-features in the noun phrase and capturing the relationship between them (e.g., by means of feature hierarchies). The

assumptions and the analysis based on them presented below have largely been chosen for reasons of concreteness and, more importantly, because they allow a clear comparison between the predictions of the NP-hypothesis and those of the DP-hypothesis. I thus do not mean to imply that the following analysis is necessarily the only and best way to tackle agreement and concord within the noun phrase. To simplify the discussion, I will in what follows ignore number agreement and focus exclusively on gender agreement, even though there is an interesting interaction between the two in BCS.²⁹

The analysis is based on the following assumptions: First, N has features for both grammatical and natural gender (Wechsler & Zlatić 2000). Second, natural gender is featurally more complex than grammatical gender as it also includes animacy. The two features will be represented as follows:

- (55) a. grammatical gender: [gen]
 b. natural/biological gender: [[gen][anim]]

A probe (A, D, V) that is searching for a gender feature can in principle target either gender. For this to be possible, the probe can be of variable complexity (so-called relativized probing, see, e.g., Nevins 2007; Béjar & Žežić 2009; Preminger 2011; probes are rendered as star-features, cf. Heck & Müller 2007).

- (56) a. simple probe (grammatical gender): [*gen:□*]
 b. complex probe (biological gender): [[*gen:□*][*anim:□*]]

Furthermore, the following assumptions hold for Relativized Minimality in the interaction of probes and goals:

- a complex probe *can* probe past a simple feature to find a complex feature below it (Relativized Minimality: a subset does not intervene)
- a simple probe *cannot* probe past a complex feature to find a simple feature (Relativized Minimality: a superset intervenes)
- a simple probe cannot be valued by a complex feature, which leads to a crash (feature copying requires matching of all features)

Importantly, the choice of probe is free, i.e., all heads that probe for phi-features (A, D, V) can enter the derivation with either a simple or a complex gender probe. As we will see, this does not lead to converging derivations in all cases.

Note that many of the assumptions above are familiar from relativized-probing based approaches to person hierarchy effects. First, the preference for agreement in a certain value is captured by both the complexity of the feature and the complexity of the probe (cf. local person, which is often analyzed as consisting of [+ participant] and [+ person]). Second, a goal that has only a subset of the probe's features cannot satisfy it (cf. 3rd person, which cannot value a probe specified for [participant]). What is different from classical cases of relativized probing for person as in Béjar & Žežić (2009) is that (i) a goal that has a superset of the features of the probe cannot value the probe (unlike a first person argument that can value a probe specified for participant) and that (ii) the gender-probe can differ in complexity. These differences are a consequence of the different workings of gender agreement in languages with hybrid agreement. The resulting system in fact also

²⁹ Grammatical agreement with hybrid nouns is only possible in the plural, see Puškar (2017; 2018) for an explicit account. Under my assumptions below, one could stipulate, e.g., by a feature-cooccurrence restriction, that the grammatical gender feature is only present in the plural with hybrid nouns. Note that that the interaction with number is not a necessary part of the phenomenon; for instance, there is no such restriction in Russian.

bears a certain similarity to the version of Relativized Minimality put forward in Starke (2001), where only supersets but not subsets intervene in movement operations.

The relevance of the complexity of probe and goal and their interaction is illustrated in the following two tree diagrams (simple probes and simple gender features are set in gray):

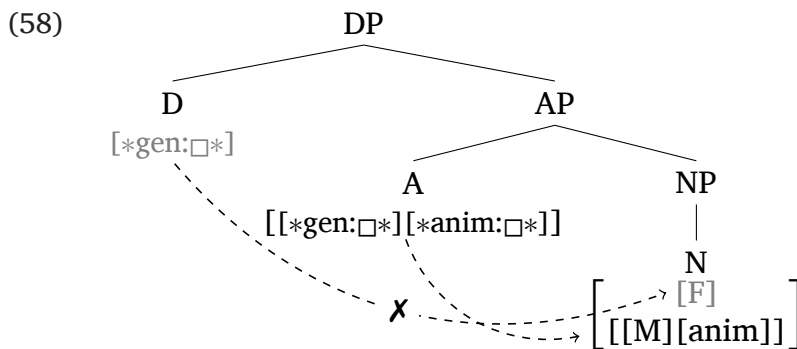
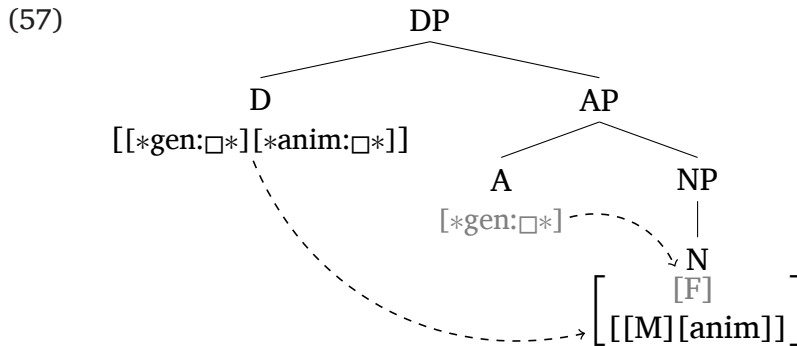

In both derivations, the adjective first agrees with the noun and copies a gender feature from it, the grammatical one in (57) and the biological one in (58). Then, the D-head probes. (57) illustrates that a complex probe can search past a simple feature. In this case we get a switch from agreement in grammatical gender to agreement in biological gender. (58) illustrates that a simple probe cannot search past a complex feature. In this case, the derivation crashes because D's feature cannot be valued (recall that since the biological gender feature contains more structure than the simple probe could accommodate, probing fails and the derivation crashes). A consequence of this is that once there has been a switch to biological agreement, the derivation will only converge if the next higher probe is complex. This captures the generalization that once there has been a switch to biological gender, there is no way back. (59) illustrates how a complex gender feature on D probes and finds the corresponding feature on A (after A has agreed with N):^{30,31}

³⁰ For the argument to go through, one has to ensure that the adjective is closer to N than D. This follows if the adjective is a head which takes the NP as its complement as originally proposed in Abney (1987: 323–334); the same assumption is made in Embick & Noyer (2001) to capture Lowering of the definite article in Bulgarian onto A and in Murphy (2018) to treat adjectival inflection in German. However, given that in languages like German adjectives can take their own complements, this appears problematic (see Hankamer & Mikkelsen 2005: 95–96 for discussion and further references; NP would arguably have to be merged as a specifier or the 'complement' of A as a specifier). Perhaps more serious is coordination of AP + NP under D and the satisfaction of Ds selectional restrictions (it selects nominals). To avoid these problems adjectives can be introduced as specifiers of a designated functional head, which takes NP as its complement. To capture the agreement facts, one then has to make sure that the features of the adjective are copied onto F and thus become visible on FP, which dominates AP and NP. Coordination below D then involves FPs and D arguably selects FPs.

³¹ I am representing the demonstratives as D-elements for simplicity's sake. This is surely not uncontroversial given that BCS is a language without articles. The fact that the switch between the demonstrative and A is easily possible but strongly disfavored between two adjectives in BCS suggests that demonstratives do belong to a different category than adjectives (even though their inflection is identical in BCS). Nothing

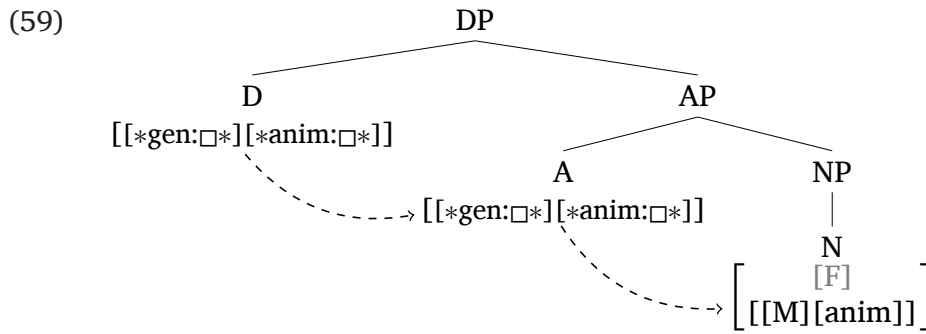

The tree diagram in (60) shows the successful derivation (52b) of (54) where the verb agrees in biological gender features:

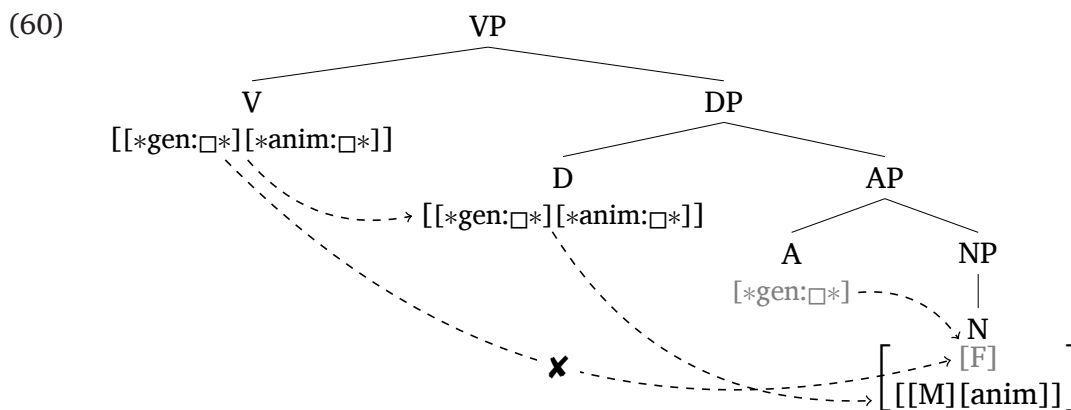

The probe on V is complex and thus targets the biological gender feature on D. Probing past D is blocked by Relativized Minimality, thus ensuring that a switch back to grammatical gender is blocked. In the alternative derivation (52d) for (54) illustrated in (61), the probe on V is simple:

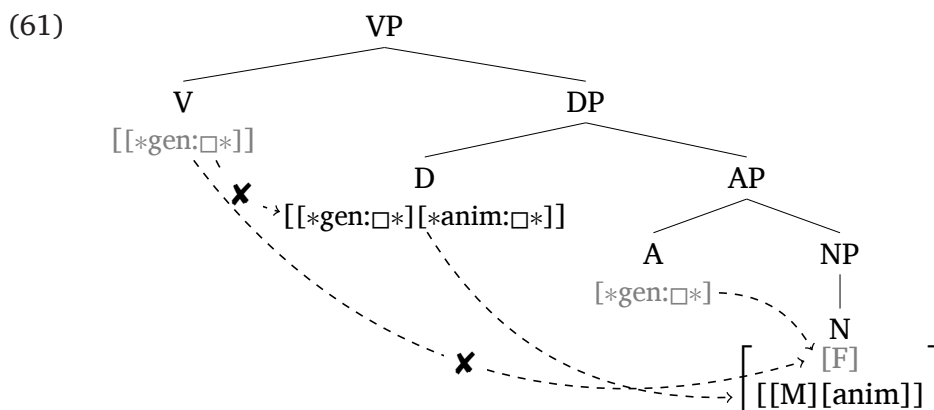

The simple probe on V cannot target the complex feature on D as it cannot accommodate both features of D. Because of Relativized Minimality, however, it cannot probe past D either, with the consequence that the probe on V remains unvalued and the derivation

much would change if the demonstratives were treated as a category separate from D, e.g., Dem. This is sufficient for present purposes: The NP-hypothesis rests on the assumption that the (lexical) noun is the head of the noun phrase. The data introduced above and analyzed below suggest that some other head in the noun phrase (viz., what can be labeled as Dem) is privileged w.r.t. agreement. This is unexpected under the NP-hypothesis.

crashes. The only converging derivation in this constellation involves a complex probe on V as illustrated in (60), resulting in biological agreement. A switch back to grammatical agreement is correctly ruled out.

Importantly, this result only follows under the DP-hypothesis because under the DP-hypothesis, D is closer to V than both A and N. Under the NP-hypothesis one would expect the reverse result: Because the features of N are present on the maximal projection, they would always be closest to outside probes like V. Consequently, one expects switching back and forth between grammatical and biological gender to be possible, contrary to fact. Since N is the closest goal for all probes in the tree, the value that obtains after Agree between A/D and N has no influence on Agree involving V – unlike in the derivation based on the DP-structure, where the earlier Agree operation affects the possibilities of the later. The tree in (62) illustrates the derivation of the ungrammatical example (52d) above with a switch to biological gender on D and a switch back to grammatical gender on V:

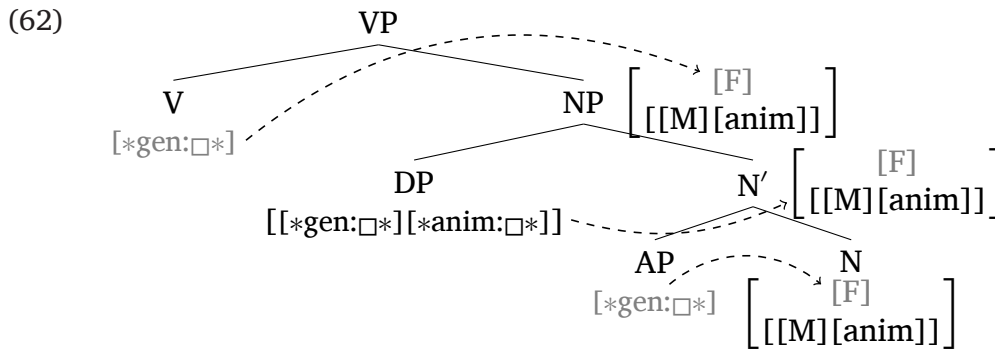

Hybrid agreement is thus a phenomenon that can be used to tease apart the NP- vs. the DP-hypothesis. Note that as discussed above, it primarily shows that N is not the head of the noun phrase but some other head such as the demonstrative. Whether one wants to call this DP is an orthogonal issue. Note that the workings of hybrid agreement thus also provide evidence against approaches like that in Bošković (2005) which treat the noun phrase in article-less languages like BCS as an NP.

4.4 A reanalysis within the NP-hypothesis?

Obviously, the argument in favor of the DP-hypothesis proposed in the previous subsection is only relevant as long as the facts cannot be reanalyzed within the NP-hypothesis. If it turns out that a plausible alternative is available, the argument will have the same status as the (putative) arguments for the DP-hypothesis discussed in Section two.

Bruening (2019; 2020) argues that it is indeed easily possible to reanalyze the agreement switches under the NP-hypothesis (I am discussing both the published version and a previous draft version since they nicely show what is at stake). In Bruening (2019), previous work on agreement switches like Matushansky (2013); Pesetsky (2013); Landau (2016) is adapted. The basic assumptions are the following: The hybrid noun starts out with a grammatical gender feature only. A biological gender feature can be introduced at any point within NP. This can be done in various ways, either by directly adding it to the projecting head (it is not shown how this can be done), by introducing it via a feature on the higher probes (i.e., adjectives, determiners, verbs etc.) as in Matushansky (2013) or by a designated functional head that bears only this feature as in Pesetsky (2013: 35–50) or by a Num-head as in Landau (2016), who discusses semantic number agreement. It is further assumed that the biological gender will be the only accessible gender feature.

In Matushansky's approach, this follows from the assumption that the biological gender feature is interpretable, while the grammatical one is uninterpretable (and by assumption a higher grammatical gender feature cannot combine with a lower biological gender feature). In the other approaches it follows under the assumption that the biological gender feature is structurally higher than the grammatical gender feature. Under these approaches, the position of the switch will thus depend on the height of the biological gender feature: If it is introduced by the determiner (Matushansky (2013)/between adjective and determiner (Pesetsky 2013, Landau 2016), probes below the determiner agree in grammatical gender, while the probes above it agree in semantic gender.

The tree diagram in (63) presents the reanalysis of the agreement involving the noun *vladika* 'bishop' within the NP-hypothesis using the mechanism proposed in Pesetsky (2013). The functional head introducing the biological gender feature is labeled 'm'.

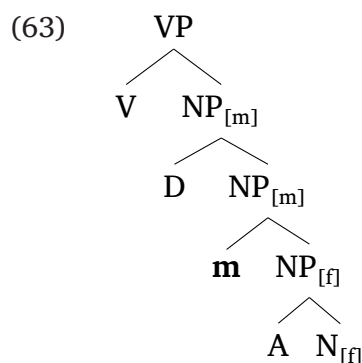

This leads to agreement in grammatical gender on the adjective and to biological gender on D and V, viz., the grammatical version (52b) of (54).

Let me discuss this alternative. It should first be pointed out that the approaches Bruening bases himself on adopt the DP-hypothesis potentially containing further functional projections. In my view this makes a non-trivial difference. At least in Landau, where Num projects to NumP and takes NP as its complement, this implies that the biological gender feature will automatically be a feature of NumP and thus of a higher projection than NP. The fact that no switch back follows naturally. Under Bruening's reanalysis, however, this is not the case, it must crucially be the non-head that imposes the biological gender feature on the head.³² In other words, under the NP-hypothesis, the agreement switch and the effects of the agreement hierarchy can only be captured if a well-established notion of headedness is given up; the approach is certainly incompatible with Bare Phrase Structure (Chomsky 1995), where the head and its projections share all features and their values. There are further arguments one can raise against these approaches and their implementation irrespective of the NP/DP debate: Under Landau's approach, to capture a switch between D and T, the gender feature would have to be introduced in a functional head above D, implying that noun phrases would not be DPs in this case but FPs/GenPs. A consequence of Matushansky's approach is the curious fact that the semantic gender feature is only found on elements where it is arguably not interpretable; this is especially clear for a semantic gender feature introduced by a verb. Finally, in all approaches, although natural masculine gender is an inherent property of

³² This also holds true of the implementation in Pesetsky (2013: 39), who writes "Once *F* merges [the functional head carrying the biological gender feature, *MS*], the nominal counts as feminine for agreement purposes from then on", although in his tree diagram the functional head does not project. In Matushansky's implementation, the biological gender feature can either be imposed by the head, e.g., when D merges with NP, or by the non-head, when an adjective merges with NP (adjectives are assumed to be adjoined to NP).

these hybrid nouns (at least of nouns like ‘bishop’), it is introduced by a separate head, which implies that some extra selectional relation (or at least some semantic restriction) must be established to ensure that this feature is only added to the right type of noun. Thus, it seems there are quite a number of reasons why one may want to prefer not to pursue this approach to agreement with hybrid nouns, not the least as it effectively seems to require a different theory of syntax, viz., one that gives up endocentricity.

Arguably for such reasons, Bruening (2020) pursues a different analysis: Phi-features on nouns are structured. Crucially, there is a higher level where phi-features are unvalued. This level dominates a level of valued features. In the case of gender, this will be grammatical and semantic gender features as in (64) for a noun like *vladika* (both features are thus on N):

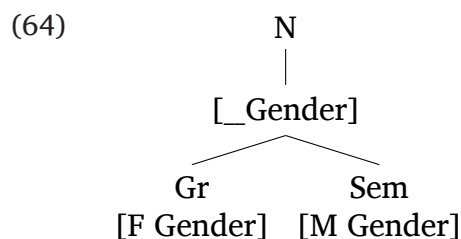

He further assumes that in principle, a probe on some higher head (A, D, V) can access either feature. However, once there has been agreement in semantic features, the gender feature on N is valued as semantic, and further Agree operations cannot probe past the valued feature; this derives the effects of the agreement hierarchy. This proposal is certainly less problematic than the previous one in that the semantic gender feature is introduced on the head it is an inherent feature of. Since the valued gender feature is present on higher projections of N, the analysis is also more endocentric. However, at the same time, it is also clear that an extra level of feature structure has to be introduced for this to work, and the valued gender feature essentially plays the role of a separate functional head above N whose function is to ensure the effects of the agreement hierarchy. None of this seems to be needed anywhere else in the grammar. Thus, eventually, it seems to me that this kind of proposal primarily highlights the difficulties that the phenomenon presents for the NP-hypothesis.

Still, while perhaps unorthodox, it is certainly a possible theory of syntax. Does this mean that the argument in favor of the DP-hypothesis introduced above is void? I think not. Theories can only be compared as long as certain assumptions are held constant, and this is what I have attempted in this paper. Once in principle anything is possible, comparison is no longer possible and no interesting arguments for any theory can be made.

5 Conclusion

I have tried to show in this chapter that many of the arguments for the DP-hypothesis that can be found in the literature are either due to specific assumptions of the GB-theory of that time or are based on presumed parallelisms between the clause and the noun phrase. As I have shown, there are reasonable reanalyses of all these phenomena within the NP-theory. Other arguments diagnose constituency rather than headedness and are thus irrelevant. The head-movement argument is among the strongest but the facts can be reanalyzed by means of reprojection. Thus, even though an analysis of these phenomena within the DP-hypothesis may be more straightforward, I take these arguments to be eventually inconclusive. This also holds for most of the few arguments in favor of the NP-hypothesis that can be found.

Thus, while most of the phenomena fail to show what they are purported to show, I have proposed that a more interesting argument for determining the head of the noun phrase can be made by relying and simple and, as far as I can tell, widely adopted assumptions

about headedness: The features of the head are present on the maximal projection. This implies that the head is closer to outside probes than other constituents of the noun phrase. This is expected to be visible in selection and agreement processes.

The situation with selection is somewhat complicated, but overall, I believe it favors the DP-hypothesis because it is more flexible to accommodate selection of noun phrases with either no determiner (pseudo-incorporated nouns, some conventionalized expressions) or a fixed determiner (weak definites, some conventionalized expressions). With respect to agreement, the head and its maximal projection are more likely to interact with noun phrase external agreement probes than material it dominates. The NP and DP hypothesis make crucially different predictions in this respect. I have shown that when this diagnostic is applied to agreement in gender with hybrid nouns in BCS, the facts favor the DP-hypothesis because the agreement switch between grammatical and biological gender agreement in BCS shows very clearly that the features of D must be closer to V than those of N. This result only obtains if D is a head above NP and DP thus dominates NP. As a final point, let me stress again, that this is not meant to imply that the DP-hypothesis is necessarily superior. Other empirical phenomena may favor the NP-hypothesis. But what I hope to have shown is how one can make an interesting argument in this debate.

Abbreviations

1/2/3 = first/second/third person, DAT = dative, DEF = definite (article or suffix), DEM = demonstrative, DET = determiner, F = feminine, GEN = genitive, INDF = indefinite, INF = infinitive, M = masculine, N = neuter, NOM = nominative, OM = object agreement marker, POSS = possessor, PRE = prefix, PRS = present, PTCP = participle, REFL = reflexive, SG = singular, SM = subject agreement marker, STR = strong (adjectival inflection), SUF = suffix, WK = weak (adjectival inflection)

AP = adjectival phrase, BCS = Bosnian-Croatian-Serbian, CP = complementizer phrase, DP = determiner phrase, GB = Government and Binding (Theory), HPSG = Head-Driven Phrase Structure Grammar, LFG = Lexical-Functional Grammar, NP = noun phrase, PossP = possessor phrase, PP = prepositional phrase, VP = verb phrase, TAG = Tree-Adjoining Grammar

Acknowledgements

Some of the ideas in this paper were presented in my seminar on the syntax of the noun phrase in the winter term 2016/17 at the University of Leipzig. I thank the participants of the seminar for helpful comments. Previous versions of this work were presented at the workshop on headedness at the Free University of Berlin (May 2017), the NP-DP workshop at the DGfS in Bremen (February 2019), and the syntax reading group at the University of Pennsylvania (September 2019). I thank the audiences at these occasions for helpful feedback; particular thanks go to Klaus Abels, Farruk Akkus, David Embick, Ulrike Freywald, Hubert Haider, Julie Legate, Stefan Müller, Martin Neef, Andreas Nolda, Andreas Pankau, and Horst Simon. My understanding of weak definites has greatly profited from conversations with Florian Schwarz, Imke Driemel and Malte Zimmermann. I also thank Benjamin Bruening for very interesting discussions about the NP-/DP-hypothesis. The paper has been substantially improved by the critical remarks and insightful suggestions of three anonymous reviewers. The usual disclaimers apply.

Funding Information

This research has been supported by the German Research Foundation (DFG) grant 2646/2-1 and the University of Pennsylvania Faculty Research Fund.

Competing Interests

The author has no competing interests to declare.

References

- Abels, Klaus. 2012. *Phases: An essay on cyclicity in syntax*. Berlin: De Gruyter. DOI: <https://doi.org/10.1515/9783110284225>
- Abels, Klaus & Ad Neeleman. 2012. Linear asymmetries and the LCA. *Syntax* 15(1). 25–74. DOI: <https://doi.org/10.1111/j.1467-9612.2011.00163.x>
- Abney, Steven. 1987. *The English noun phrase in its sentential aspect*. Cambridge MA: MIT dissertation.
- Ackema, Peter & Ad Neeleman. 2004. *Beyond morphology: Interface conditions on word formation*. Oxford: Oxford University Press. DOI: <https://doi.org/10.1093/acprof:oso/9780199267286.001.0001>
- Adger, David. 2003. *Core syntax: A minimalist approach*. Oxford: Oxford University Press.
- Aguilar-Guevara, Ana. 2014. *Weak definites: Semantics, lexicon and pragmatics*. Utrecht: LOT.
- Alexiadou, Artemis, Haegeman Liliane & Stavrou Melita. 2007. *Noun phrase in the generative perspective*. Berlin: Mouton de Gruyter. DOI: <https://doi.org/10.1515/9783110207491>
- Assmann, Anke, Doreen Georgi & Philipp Weisser. 2012. A minimalist analysis of possessor advancement: Baker (1988) revisited. In Enrico Boone, Kathrin Linke & Maartje Schulpen (eds.), *Proceedings of ConSOLE XIX (2011, Groningen)*, 77–103. Leiden: SOLE.
- Baker, Mark C. 1988. *Incorporation: A theory of grammatical function changing*. Chicago: University of Chicago Press.
- Barrie, Michael & Eric Mathieu. 2016. Noun incorporation and phrasal movement. *Natural Language & Linguistic Theory* 34(1). 1–51. DOI: <https://doi.org/10.1007/s11049-015-9296-6>
- Béjar, Susana & Milan Řezáč. 2009. Cyclic Agree. *Linguistic Inquiry* 40. 35–73. DOI: <https://doi.org/10.1162/ling.2009.40.1.35>
- Bernstein, Judy B. 2001. The DP hypothesis: Identifying clausal properties in the nominal domain. In Mark Baltin & Chris Collins (eds.), *The handbook of contemporary syntactic theory*, 536–561. Malden, MA: Blackwell. DOI: <https://doi.org/10.1002/9780470756416.ch17>
- Bošković, Željko. 2005. On the locality of left branch extraction and the structure of NP. *Studia Linguistica* 59(1). 1–45. DOI: <https://doi.org/10.1111/j.1467-9582.2005.00118.x>
- Bošković, Željko. 2006. Case and agreement with genitive of quantification in Russian. In Cedric Boeckx (ed.), *Agreement systems*, 99–121. Amsterdam/Philadelphia: John Benjamins. DOI: <https://doi.org/10.1075/la.92.07bos>
- Bošković, Željko. 2009. More on the no-DP analysis of article-less languages. *Studia Linguistica* 63(2). 187–203. DOI: <https://doi.org/10.1111/j.1467-9582.2009.01158.x>
- Bošković, Željko. 2016. Getting really edgy: On the edge of the edge. *Linguistic Inquiry* 47(1). 1–33. DOI: https://doi.org/10.1162/LING_a_00203
- Bresnan, Joan, Ash Asudeh, Ida Toivonen & Stephen Wechsler. 2016. *Lexical-functional syntax*. Malden, MA: Wiley Blackwell. DOI: <https://doi.org/10.1002/9781119105664>
- Bruening, Benjamin. 2009. Selectional asymmetries between CP and DP suggest that the DP hypothesis is wrong. In Laurel MacKenzie (ed.), *University of Pennsylvania Working Papers in Linguistics 15.1: Proceedings of the 32nd Annual Penn Linguistics Colloquium*, 26–35. Philadelphia: University of Pennsylvania.

- Bruening, Benjamin. 2019. The DP hypothesis has no defense: N-to-D movement, hybrid agreement, and conventionalized expressions. Ms. University of Delaware. DOI: <https://doi.org/10.5334/gjgl.1031>
- Bruening, Benjamin. 2020. The head of the nominal is N, not D: N-to-D movement, hybrid agreement, and conventionalized expressions. *Glossa: A Journal of General Linguistics* 5(1), 15. DOI: <https://doi.org/10.5334/gjgl.1031>
- Bruening, Benjamin, Xuyen Dinh & Lan Kim. 2018. Selection, idioms, and the structure of nominal phrases with and without classifiers. *Glossa: a journal of general linguistics* 3(1) (42). 1–46. DOI: <https://doi.org/10.5334/gjgl.288>
- Carstens, Vicki. 2017. Noun-to-determiner movement. In Martin Everaert & Henk van Riemsdijk (eds.), *The Wiley Blackwell companion to syntax*. 2nd edition. Volume V, 2758–2783. Somerset, NJ: John Wiley. DOI: <https://doi.org/10.1002/9781118358733.wbsyncom120>
- Chomsky, Noam. 1973. Conditions on transformations. In Stephen R. Anderson & Paul Kiparsky (eds.), *A festschrift for Morris Halle*, 232–286. New York: Holt, Rinehart and Winston.
- Chomsky, Noam. 1995. *The minimalist program*. Cambridge, MA: MIT Press.
- Chomsky, Noam. 2001. Derivation by phase. In Michael Kenstowicz (ed.), *Ken Hale: A life in language*, 1–52. Cambridge, MA: MIT Press.
- Cinque, Guglielmo. 2005. Deriving Greenberg’s universal 20 and its exceptions. *Linguistic Inquiry* 36(3). 315–332. DOI: <https://doi.org/10.1162/0024389054396917>
- Coene, Martine & Yves d’Hulst. 2003. Introduction: The syntax and semantics of noun phrases. Theoretical background. In Martine Coene & Yves d’Hulst (eds.), *From NP to DP. Volume 1: The syntax and semantics of noun phrases*, 1–33. Amsterdam: John Benjamins. DOI: <https://doi.org/10.1075/la.55.01coe>
- Corbett, Greville G. 2006. *Agreement*. Cambridge: Cambridge University Press.
- Cowper, Elizabeth A. 1987. Pied piping, feature percolation and the structure of the noun phrase. *Canadian Journal of Linguistics/Revue Canadienne de Linguistique* 32(4). 321–338. DOI: <https://doi.org/10.1017/S0008413100012433>
- Danon, Gabi. 2006. Caseless nominals and the projection of DP. *Natural Language & Linguistic Theory* 24(4). 977–1008. DOI: <https://doi.org/10.1007/s11049-006-9005-6>
- Danon, Gabi. 2011. Agreement and DP-internal feature distribution. *Syntax* 14(4). 297–317. DOI: <https://doi.org/10.1111/j.1467-9612.2011.00154.x>
- Dayal, Veneeta. 2011. Hindi pseudo-incorporation. *Natural Language & Linguistic Theory* 29(1). 123–167. DOI: <https://doi.org/10.1007/s11049-011-9118-4>
- Déchainé, Rose-Marie & Martina Wiltschko. 2002. Decomposing pronouns. *Linguistic Inquiry* 33(3). 409–442. DOI: <https://doi.org/10.1162/002438902760168554>
- Elbourne, Paul D. 2005. *Situations and individuals*. Cambridge, MA: MIT Press.
- Embick, David. 2000. Features, syntax, and categories in the Latin perfect. *Linguistic Inquiry* 31(2). 185–230. DOI: <https://doi.org/10.1162/002438900554343>
- Embick, David. 2007. Linearization and local dislocation: Derivational mechanics and interactions. *Linguistic Analysis* 33(3–4). 303–336.
- Embick, David & Rolf Noyer. 2001. Movement operations after syntax. *Linguistic Inquiry* 32(4). 555–595. DOI: <https://doi.org/10.1162/002438901753373005>
- Ernst, Thomas Boyden. 2002. *The syntax of adjuncts*. Cambridge: Cambridge University Press.
- Erschler, David. 2019. A new argument for existence of the DP in languages without articles. *Journal of Linguistics* 55(4). 879–887. DOI: <https://doi.org/10.1017/S0022226719000288>
- Frank, Robert. 2002. *Phrase structure composition and syntactic dependencies*. Cambridge, MA: MIT Press. DOI: <https://doi.org/10.7551/mitpress/5366.001.0001>

- Georgi, Doreen & Gereon Müller. 2010. Noun-phrase structure by reprojection. *Syntax* 13(1). 1–36. DOI: <https://doi.org/10.1111/j.1467-9612.2009.00132.x>
- Georgi, Doreen & Martin Salzmann. 2011. DP-internal double agreement is not double agree: Consequences of Agree-based case assignment within DP. *Lingua* 121(14). 2069–2088. DOI: <https://doi.org/10.1016/j.lingua.2011.07.010>
- Grohmann, Kleanthes K. 2003. Successive cyclicity under (anti-)local considerations. *Syntax* 6(3). 260–312. DOI: <https://doi.org/10.1111/j.1467-9612.2003.00063.x>
- Haider, Hubert. 1992. Die Struktur der Nominalphrase – lexikalische undfunktionale Strukturen. In Ludger Hoffmann (ed.), *Deutsche Syntax: Ansichten und Aussichten. Jahrbuch 1991 des Instituts für deutsche Sprache*, 304–333. Berlin: De Gruyter. DOI: <https://doi.org/10.1515/9783110622447-013>
- Haider, Hubert. 2000. Branching and discharge. In Peter Coopmans, Martin Everaert & Jane Grimshaw (eds.), *Lexical specification and insertion*, 135–164. Amsterdam: John Benjamins.
- Halle, Morris & Alec Marantz. 1993. Distributed morphology and the pieces of inflection. In Ken Hale & Samuel Jay Keyser (eds.), *The view from building 20: Essays in linguistics in honour of Sylvain Bromberger*, 111–176. Cambridge, MA: MIT Press.
- Hankamer, Jorge & Line Mikkelsen. 2005. When movement must be blocked: A reply to Embick and Noyer. *Linguistic Inquiry* 36(1). 85–125. DOI: <https://doi.org/10.1162/0024389052993664>
- Heck, Fabian & Anke Himmelreich. 2017. Opaque intervention. *Linguistic Inquiry* 48(1). 47–97. DOI: https://doi.org/10.1162/LING_a_00235
- Heck, Fabian & Gereon Müller. 2007. Extremely local optimization. *Proceedings of WECOL 17*. 170–182.
- Hornstein, Norbert, Kleanthes K. Grohmann & Jairo Nunes. 2005. *Understanding minimalism*. Cambridge: Cambridge University Press. DOI: <https://doi.org/10.1017/CBO9780511840678>
- Jackendoff, Ray. 1977. *X' syntax: A study of phrase structure*. Cambridge, MA: MIT Press.
- Jenks, Peter. 2018. Articulated definiteness without articles. *Linguistic Inquiry* 49(3). 501–536. DOI: https://doi.org/10.1162/ling_a_00280
- Kallulli, Dalina. 1999. *The comparative syntax of Albanian: On the contribution of syntactic types to propositional interpretation*. Durham: University of Durham dissertation.
- Kallulli, Dalina. 2008. There is secondary predication in there-existentials. In Charles B. Chang & Hannah J. Haynie (eds.), *Proceedings of the 26th West Coast Conference on Formal Linguistics*, 279–287. Somerville, MA: Cascadilla Proceedings Project.
- Kayne, Richard S. 1994. *The antisymmetry of syntax*. Cambridge, MA: MIT Press.
- Kiss, Katalin É. 2002. *The syntax of Hungarian*. Cambridge: Cambridge University Press. DOI: <https://doi.org/10.1017/CBO9780511755088>
- Landau, Idan. 2016. DP-internal semantic agreement: A configurational analysis. *Natural Language & Linguistic Theory* 34(3). 975–1020. DOI: <https://doi.org/10.1007/s11049-015-9319-3>
- Larson, Richard. to appear. The DP hypothesis and (a)symmetries between DP and CP. *Linguistic Analysis* 42(3–4).
- Longobardi, Giuseppe. 1994. Reference and proper names: A theory of N-movement in syntax and logical form. *Linguistic Inquiry* 25(4). 609–665.
- Longobardi, Giuseppe. 2001. The structure of DPs: Some principles, parameters and problems. In Mark Baltin & Chris Collins (eds.), *The handbook of contemporary syntactic theory*, 562–603. Malden, MA: Blackwell. DOI: <https://doi.org/10.1002/9780470756416.ch18>

- Massam, Diane. 2001. Pseudo noun incorporation in Niuean. *Natural Language & Linguistic Theory* 19(1). 153–197. DOI: <https://doi.org/10.1023/A:1006465130442>
- Matushansky, Ora. 2013. Gender confusion. In Lisa Cheng & Norbert Corver (eds.), *Diagnosing syntax*, 271–294. Oxford: Oxford University Press. DOI: <https://doi.org/10.1093/acprof:oso/9780199602490.003.0013>
- Müller, Gereon. 2010a. Movement from verb-second clauses revisited. In Thomas Hanneforth & Gisbert Fanselow (eds.), *Language and logos: Studies in theoretical and computational linguistics*, 97–128. Berlin: Akademie Verlag.
- Müller, Gereon. 2010b. On deriving CED effects from the PIC. *Linguistic Inquiry* 41(1). 35–82. DOI: <https://doi.org/10.1162/ling.2010.41.1.35>
- Müller, Stefan. 2007. *Head-Driven Phrase Structure Grammar: Eine Einführung*. Tübingen: Stauffenburg.
- Murphy, Andrew. 2018. Pronominal inflection and NP ellipsis in German. *The Journal of Comparative Germanic Linguistics* 21(3). 327–379. DOI: <https://doi.org/10.1007/s10828-018-9102-z>
- Nevins, Andrew. 2007. The representation of third person and its consequences for person-case effects. *Natural Language & Linguistic Theory* 25(2). 273–313. DOI: <https://doi.org/10.1007/s11049-006-9017-2>
- Ott, Dennis. 2015. Symmetric merge and local instability: Evidence from split topics. *Syntax* 18(2). 157–200. DOI: <https://doi.org/10.1111/synt.12027>
- Patel-Grosz, Pritty & Patrick Georg Grosz. 2017. Revisiting pronominal typology. *Linguistic Inquiry* 48(2). 259–297. DOI: https://doi.org/10.1162/LING_a_00243
- Pereltsvaig, Asya. 2006. Small nominals. *Natural Language & Linguistic Theory* 24(2). 433–500. DOI: <https://doi.org/10.1007/s11049-005-3820-z>
- Pesetsky, David. 2013. *Russian case morphology and the syntactic categories*. Cambridge, MA: MIT Press. DOI: <https://doi.org/10.7551/mitpress/9780262019729.001.0001>
- Preminger, Omer. 2011. *Agreement as a fallible operation*. Cambridge, MA: MIT dissertation.
- Punske, Jeffrey. 2014. Functional structure inside nominal phrases. In Andrew Carnie, Yosuke Sato & Daniel Siddiqi (eds.), *The Routledge handbook of syntax*, 65–88. London/New York: Routledge.
- Puškar, Zorica. 2017. *Hybrid agreement: Modelling variation, hierarchy effects and ϕ -feature mismatches*. Leipzig: Leipzig University dissertation.
- Puškar, Zorica. 2018. Interactions of gender and number agreement: Evidence from Bosnian/Croatian/Serbian. *Syntax* 21(3). 275–318. DOI: <https://doi.org/10.1111/synt.12154>
- Ritter, Elizabeth. 1988. A head-movement approach to construct-state noun phrases. *Linguistics* 26(6). 909–930. DOI: <https://doi.org/10.1515/ling.1988.26.6.909>
- Rosen, Sara Thomas. 1989. Two types of noun incorporation: A lexical analysis. *Language* 65(2). 294–317. DOI: <https://doi.org/10.2307/415334>
- Saab, Andrés. 2019. Nominal ellipsis. In Jeroen van Craenenbroeck & Tanja Temmerman (eds.), *The Oxford handbook of ellipsis*, 526–561. Oxford: Oxford University Press. DOI: <https://doi.org/10.1093/oxfordhb/9780198712398.013.26>
- Sag, Ivan A., Thomas Wasow & Emily M. Bender. 2003. *Syntactic theory: A formal introduction*. Stanford, CA: CSLI Publications.
- Schoorlemmer, Erik. 2009. *Agreement, dominance and doubling*. Utrecht: LOT.
- Schoorlemmer, Erik. 2012. Definiteness marking in Germanic: Morphological variations on the same syntactic theme. *The Journal of Comparative Germanic Linguistics* 15(2). 107–156.

- Schwarz, Florian. 2009. *Two types of definites in natural language*. Amherst, MA: University of Massachusetts, Amherst Doctoral dissertation. DOI: <https://doi.org/10.1007/s10828-012-9048-5>
- Schwarz, Florian. 2014. How weak and how definite are weak definites? In Ana Aguilar-Guevara, Bert Le Bruyn & Joost Zwarts (eds.), *Weak referentiality*, 213–235. Amsterdam/Philadelphia: John Benjamins.
- Scott, Gary-John. 2002. Stacked adjectival modification and the structure of nominal phrases. In Guglielmo Cinque (ed.), *Functional structure in the DP and IP: The cartography of syntactic structures 1*, 91–120. Oxford: Oxford University Press. DOI: <https://doi.org/10.1075/la.219.09sch>
- Starke, Michal. 2001. *Move dissolves into merge: A theory of locality*. Geneva: University of Geneva dissertation.
- Sternefeld, Wolfgang. 2004. Feature checking, case, and agreement in German DPs. In Gereon Müller, Lutz Gunkel & Gisela Zifonun (eds.), *Explorations in nominal inflection*, 269–299. Berlin: Mouton de Gruyter.
- Sternefeld, Wolfgang. 2006. *Syntax: Eine morphologisch motivierte generative Beschreibung des Deutschen*. Tübingen: Stauffenburg Verlag. DOI: <https://doi.org/10.1515/9783110197501.269>
- Travis, Lisa. 1984. *Parameters and effects of word order variation*. Cambridge, MA: MIT dissertation.
- van Riemsdijk, Henk. 1998. Head movement and adjacency. *Natural Language & Linguistic Theory* 16(3). 633–679. DOI: <https://doi.org/10.1023/A:1006075919357>
- Wechsler, Stephen & Larisa Zlatić. 2000. A theory of agreement and its application to Serbo-Croatian. *Language* 76(4). 799–832. DOI: <https://doi.org/10.2307/417200>
- Wiltschko, Martina. 1998. On the syntax and semantics of (relative) pronouns and determiners. *The Journal of Comparative Germanic Linguistics* 2(2). 143–181. DOI: <https://doi.org/10.1023/A:1009719229992>
- Wurmbrand, Susi. 2012. Parasitic participles in Germanic: Evidence for the theory of verb clusters. *Taal en Tongval: Tijdschrift voor Taalvariatie* 64(1). 129–156. DOI: <https://doi.org/10.5117/TET2012.1.WURM>

How to cite this article: Salzmann, Martin. 2020. The NP vs. DP debate. Why previous arguments are inconclusive and what a good argument could look like. Evidence from agreement with hybrid nouns. *Glossa: a journal of general linguistics* 5(1): 83.1–46. DOI: <https://doi.org/10.5334/gjgl.1123>

Submitted: 02 October 2019 **Accepted:** 25 May 2020 **Published:** 21 August 2020

Copyright: © 2020 The Author(s). This is an open-access article distributed under the terms of the Creative Commons Attribution 4.0 International License (CC-BY 4.0), which permits unrestricted use, distribution, and reproduction in any medium, provided the original author and source are credited. See <http://creativecommons.org/licenses/by/4.0/>.



Glossa: a journal of general linguistics is a peer-reviewed open access journal published by Ubiquity Press.

OPEN ACCESS